

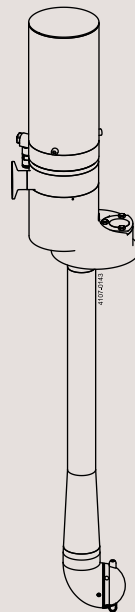

Instruction Manual

Alfa Laval Toftejorg™ SaniJet 20 Air Driven



Covering: Standard, Hastelloy

Q-doc: Equipment Doc (3.1 Inspection Certificate - EN 10204)

Q-doc+FAT-SAT: Qualification Documentation incl. FAT and SAT)

Improved surface finish (0.5 µm Ra internal/external media contact parts)

Machines delivered with ATEX/IECEX Certification in accordance with Directive 2014/34/EU

First published: 04-2009

ESE01829-EN19

2025-10

Original manual

The information herein is correct at the time of issue but may be subject to change without prior notice

1. Declarations of Conformity	5
2. Safety	7
2.1. Important information	7
2.2. Warning signs	7
3. Introduction	8
3.1. Introduction	8
3.2. Intended Use	8
3.3. Patents and Trademarks	9
3.4. Reserved rights for design changes	9
3.5. Marking	9
3.6. ATEX/IECEX marking	10
3.7. ATEX/IECEX temperature class and code	12
3.8. Quality system	13
4. Installation	14
4.1. General description	14
4.2. Functioning	15
4.3. Installation of Air Motor	18
4.4. General safety and installation instructions	20
4.5. Specific conditions for safe use in accordance with ATEX/IECEX certification	21
5. Operation	24
5.1. Normal operation	24
5.2. Normal Operation of Air Motor	25
5.3. Safety Precautions	26
6. Maintenance	27
6.1. Preventive Maintenance	27
6.2. Reserved rights for design changes of Alfa Laval equipment used in validated processes	27
6.3. Preventive Maintenance of Air Motor	28
6.4. Service and repair of ATEX/IECEX certified machines	29
6.5. Service and repair of machines ordered with Q-doc and with Q-doc + FAT-SAT	30
6.6. Every 300 working hours	31
6.7. Cleaner Head Unit - dismantling and reassembling	32
6.8. Base Unit - Dismantling and Reassembling	33
6.9. Air Motor Drive Unit - dismantling and reassembling	34
6.10. Rotacheck System	35
7. Trouble shooting guide	36
8. Technical data	37
9. Product programme	41
9.1. Standard configurations	41
9.2. Available add-ons	43
9.3. Available add-ons for spare parts	44
9.4. Accessories	44
10. Parts drawings and lists, service kits and tools	45
10.1. Toftejorg SaniJet 20, Air Driven (EPDM as standard)	45
10.2. Toftejorg SaniJet 20 Air Driven improved surface finish (EPDM as standard)	48

Table of contents

The information herein is correct at the time of issue but may be subject to change without prior notice

10.3. Toftejorg SaniJet 20 Air Driven Hastelloy (FFKM as standard)	51
10.4. Toftejorg SaniJet 20 Air Driven Hastelloy improved surface finish (FFKM as standard)	54
10.5. Service kits	57
10.6. Tools	58
11. General information	59
11.1. Service and repair	59
11.2. How to order spare parts	59
11.3. How to contact Alfa Laval Kolding A/S	59

1 Declarations of Conformity

EU Declaration of Conformity

The Designated Company

Alfa Laval Kolding A/S, Albuen 31, DK-6000 Kolding, Denmark, +45 79 32 22 00

Company name, address and phone number

Hereby declare that

Rotary Jet Head

Designation

SaniJet 20 Air, SaniJet 20 Air UP

Type

Serial number from 2019-0001 to 2030-99999

is in conformity with the following directives with amendments:

- Machinery Directive 2006/42/EC

- ATEX Directive 2014/34/EU and the following harmonized standards are used:

EN ISO 80079-36:2016, EN ISO 80079-37:2016, DS/EN ISO/IEC 80079-34:2011, Annex A, paragraph A.5.3 Rotating machines

SaniJet 20 A, Tank cleaning unit

EC Type Examination Certificate no. Baseefa05ATEX0117X and IECEx BAS 19.0063X

Marking:  II 1G Ex h IIC 85°C... 175°C Ga
II 1D Ex h IIIC T85°C... T140°C Da

The QAN (Quality Assurance Notification) is carried out by SGS Fimko Oy, Särkiniementie 3, Helsinki 00211, Finland. Notified Body No. 0598.
EU Type Examination Certification is carried out by SGS Fimko Oy, Särkiniementie 3, Helsinki 00211, Finland. Notified Body no. 0598.
IECEx Certificate of Conformity is carried out by Baseefa Ltd., Rockhead Business Park, Staden Lane, Buxton, Derbyshire SK17 9RZ, United Kingdom. IECEx Accepted Certification Body (ExCB).

SaniJet 20 A, Air Motor Unit

Archive no.: DTI-2013-1-0148A

Marking:  II 2G Ex h IIC T4 Gb
II 2D Ex h IIIC T135°C Db

Archived at Dancert A/S. Certification body number 1073, Gregersensvej, 2630 Taastrup, Denmark.

The person authorised to compile the technical file is the signer of this document.

Vice President BU Hygienic Fluid Handling
Head of Product Management

Title

Mikkel Nordkvist

Name

Kolding, Denmark

Place

2025-10-08

Date (YYYY-MM-DD)



Signature

DoC Revision_02_102025



1 Declarations of Conformity

UK Declaration of Conformity

The Designated Company

Alfa Laval Kolding A/S, Albuen 31, DK-6000 Kolding, Denmark, +45 79 32 22 00

Company name, address and phone number

Hereby declare that

Rotary Jet Head

Designation

SaniJet 20 Air, SaniJet 20 Air UP

Type

Serial number from 2019-0001 to 2030-99999

is in conformity with the following directives with amendments:

- The Supply of Machinery (Safety) Regulations 2008
 - The Equipment and Protective Systems Intended for use in Potentially Explosive Atmospheres Regulations 2016
- and the following harmonized standards are used: EN ISO 80079-36:2016, EN ISO 80079-37:2016, DS/EN ISO/IEC 80079-34:2011, Annex A, paragraph A.5.3 Rotating machines

SaniJet 20 A, Tank cleaning unit

EC Type Examination Certificate no. Baseefa05ATEX0117X and IECEx BAS 19.0063X

Marking:  II 1G Ex h IIC 85°C... 175°C Ga
II 1D Ex h IIIC T85°C... T140°C Da

The QAN (Quality Assurance Notification) is carried out by SGS Fimko Oy, Särkiniementie 3, Helsinki 00211, Finland. Notified Body No. 0598. EU Type Examination Certification is carried out by SGS Fimko Oy, Särkiniementie 3, Helsinki 00211, Finland. Notified Body no. 0598. IECEx Certificate of Conformity is carried out by Baseefa Ltd., Rockhead Business Park, Staden Lane, Buxton, Derbyshire SK17 9RZ, United Kingdom. IECEx Accepted Certification Body (ExCB).

SaniJet 20 A, Air Motor Unit

Archive no.: DTI-2013-1-0148A

Marking:  II 2G Ex h IIC T4 Gb
II 2D Ex h IIIC T135° Db

Archived at Dancert A/S. Certification body number 1073, Gregersensvej, 2630 Taastrup, Denmark.

Signed on behalf of: Alfa Laval Kolding A/S

Vice President BU Hygienic Fluid Handling
Head of Product Management

Title

Mikkel Nordkvist
Name

Kolding, Denmark
Place

2025-10-08
Date (YYYY-MM-DD)

Signature

DoC Revison_03_102025



Unsafe practices and other important information are emphasized in this manual.

Warnings are emphasized by means of special signs.

Always read the manual before using the tank cleaning machine!

2.1 Important information

WARNING

Indicates that special procedures must be followed to avoid serious personal injury.

CAUTION

Indicates that special procedures must be followed to avoid damage to the tank cleaning machine

NOTE

Indicates important information to simplify or clarify procedures.

2.2 Warning signs

General warning:



ATEX/IECEx warning:



3 Introduction

Tottejorg SaniJet 20 Air driven

3.1 Introduction

This manual has been prepared as a guide for installation and for the persons who will be operating and maintaining your tank cleaning machine. The key to long life for your tank cleaning machine is a carefully planned system for preventive maintenance; you must appreciate that a tank cleaning machine which has a rough and dirty job to do will need more frequent attention than one working under ideal conditions.

NOTE

Get the best and most economical performance from your tank cleaning machine. Insufficient preventive maintenance means poor performance, unscheduled stops, shorter lifetime and extra costs. Good preventive maintenance on the contrary means good performance, no unscheduled stops and superior total economy.

Should you require further assistance, our Technical Sales Support department and worldwide net of sales offices will be pleased to help you. Please quote the type, article and serial numbers with all of your enquiries; this helps us to help you. The type, article and serial numbers are laser engraved on the Base house of the tank cleaning machine. For more information on marking position see section 3.5 Marking and 3.6 ATEX/IECEX marking.

Warning:



Before installing the machine and setting it into operation carefully read the General safety and installation instructions (page 20) and the specific conditions for safe use in accordance with ATEX/IECEX directive 2014/34/EU (page 21) and take all necessary precautions according to your application and local regulations.

NOTE

The illustrations and specifications contained in this manual were effective at the date of printing. However, as continuous improvements are our policy, we reserve the right to alter or modify any unit specification on any product without prior notice or any obligation.

The English version of the instruction manual is the original manual. We make reservations in regard to possible mistranslations in language versions of the instruction manual. In case of doubt, the English version of the instruction manual applies.

3.2 Intended Use

It is to be verified by the end-user:

- that the tank cleaning machine is in conformity with respect to tank, vessel or container size in which it will be used.
- that the construction materials (both metallic and non-metallic) are compatibility with product, flushing media, cleaning media, temperatures and pressure under the intended use.

The tank cleaning machine mixer is intended for use in closed tank, vessel or container. If used in open environment see 4.4 General safety and installation instructions (page 20).

3.3 Patents and Trademarks

This Instruction Manual is published by Alfa Laval Kolding A/S without any warranty. Improvements and changes to this Instruction Manual may at any time be made by Alfa Laval Kolding A/S without prior notice. Such changes will, however, be incorporated in new editions of this Instruction Manual.

Alfa Laval Kolding A/S. All rights reserved.

The Alfa Laval logotype is a trademark or a registered trademark of Alfa Laval Corporate AB. "Toftejorg" and "SaniJet" are trademarks or registered trademarks of Alfa Laval Kolding A/S. The Toftejorg™ SaniJet 20 product has patents in the EPO member states, in the US and in other countries. Other products or company names mentioned herein may be the trademarks of their respective owners. Any rights not expressly granted herein are reserved.

3.4 Reserved rights for design changes

Alfa Laval is continuously working on improving our equipment and services. In this improvement work Alfa Laval may for example change the design and material in our equipment. A change in the design will not necessarily entail a change of the specification and item no. for the equipment.

Alfa Laval reserves the right to change the design of Alfa Laval equipment without any notifications for improvements of our design.

If Equipment from Alfa Laval is used in connection with, for example, a validated plant, and an order for replacements is made, the design of the replacement may have been changed even if the specifications /item no. is the same as the existing installed and validated ones.

When ordering a replacement please contact Alfa Laval sales support in this matter before placing the order.

3.5 Marking

Alfa Laval tank cleaning machines are marked to allow for recognition of type of machine, machine name, serial number and manufacturing address.

The marking is placed on the base house of the tank cleaning machine.

Rotary Jet Head
SaniJet 20
s/n.: yyyy-xxxxx
Alfa Laval, DK-6000 Kolding, Albuen 31
CE

Serial number explanation

Machines supplied with or without standard documentation:

yyyy-xxxxx: serial number

yyyy: year

xxxxx: 5 digit sequential number

3 Introduction

Toftejorg SaniJet 20 Air driven

3.6 ATEX/IECEX marking

Cleaner unit

The Alfa Laval Toftejorg SaniJet 20A Cleaner unit is certified as category I component. The ATEX certification is carried out by the Notified Body SGS Fimko Oy, who has issued the certificate no. Baseefa05ATEX0117X.

The IECEX certification is carried out by the Certification Body SGS Baseefa Ltd., who has issued the certificate no. IECEX BAS 19.0063X.

Note

Explosion protection type is constructional safety "c".

The marking on the ATEX/IECEX certified Alfa Laval Toftejorg SaniJet 20 is as follows (for information on marking position see next page):

Rotary Jet Head

SaniJet 20

s/n.: yyyy-xxxxx



Temp. operation: Max. 90°C
Temp. ambient: Max. 140°C
Pressure: Max. 13 bar

Rotary Jet Head

SaniJet 20

s/n.: yyyy-FAT-SAT-xxx

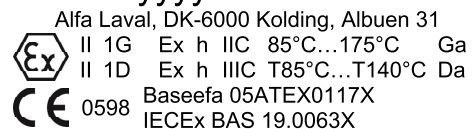

Temp. operation: Max. 90°C
Temp. ambient: Max. 140°C
Pressure: Max. 13 bar

Serial number explanation

Machines supplied with or without standard documentation:

yyyy-xxxxx: serial number

yyyy: year

xxxxx: 5 digit sequential number

Serial number explanation

Machines supplied with Q-doc + FAT-SAT documentation:

yyyy-FAT-SAT-xxx: serial number

yyyy: year

xxx: 3 digit sequential number

Drive unit

The Alfa Laval Toftejorg SaniJet 20A Air drive unit is certified as category 2 component for installation in zone 1/21 (outside tank) in accordance with Directive 2014/34/EU. The certification is carried out by Alfa Laval as a Own Assessment and archived at Dancert A/S. Certification body number 1073, Gregersensvej, 2630 Taastrup, Denmark. Registered as archive no.: DTI-2013-1-0148A.

The marking on the ATEX/IECEX certified Alfa Laval Toftejorg SaniJet 20A Air drive unit is as follows (for information on marking position see next page):



Marking positions:

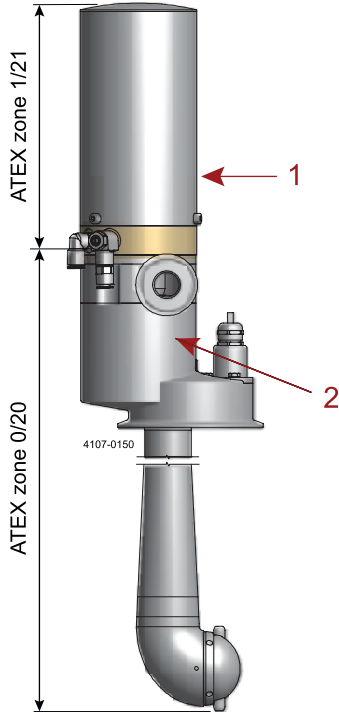

1. Drive unit



SaniJet 20A, Air motor

Alfa Laval, DK-6000 Kolding, Albuen 31

Ex II 2G Ex h IIC T4 Gb
II 2D Ex h IIIIC T135°C Db

2. Cleaner unit

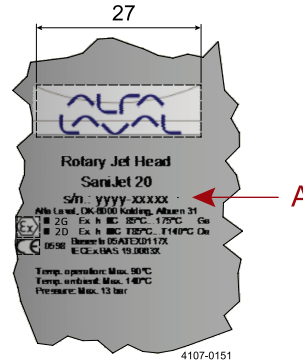

A: For FAT-SAT machines with index no. -6x,
the s/n must be yyy-FAT-SAT-xxx

3 Introduction

Tottejorg SaniJet 20 Air driven

3.7 ATEX/IECEx temperature class and code

NOTE

The Air Drive unit is only approved for use in zone 1/21 (outside the tank). Whereas the Tank cleaning unit is approved for use in zone 0/20.

When determining the temperature class for zone 1/21 (outside tank), both the temperature class for the Tank cleaning unit and the Air drive unit must be considered.

3.7.1 Tank cleaning unit

The maximum surface temperature for the Tank cleaning unit depends mainly on operating conditions which are the temperature of the cleaning fluid and the ambient temperature.

Group II EPL Ga

The gas temperature class is corrected with a safety margin of 80% due to a requirement for Group II EPL Ga equipment. The gas temperature class depends on the cleaning fluid temperature or the ambient temperature, whichever of the two is the highest.

Table for determining temperature class (gas atmospheres)		
Gas Temperature class	Cleaning fluid temperature, T_p (°C)	Ambient temperature, T_{amb} (°C)
85°C (T6)	$\leq +68^\circ\text{C}$	$\leq +68^\circ\text{C}$
100°C (T5)	$\leq +80^\circ\text{C}$	$\leq +80^\circ\text{C}$
135°C (T4)	$\leq +108^\circ\text{C}$	$\leq +108^\circ\text{C}$
175°C	$\leq +140^\circ\text{C}$	$\leq +140^\circ\text{C}$

Group III EPL Da

The dust temperature class depends on the cleaning fluid temperature or the ambient temperature, whichever of the two is the highest. No dust layer is considered.

Table for determining temperature class (dust atmospheres)		
Dust Temperature code	Cleaning fluid temperature, T_p (°C)	Ambient temperature, T_{amb} (°C)
T85°C	$\leq +85^\circ\text{C}$	$\leq +85^\circ\text{C}$
T100°C	$\leq +100^\circ\text{C}$	$\leq +100^\circ\text{C}$
T135°C	$\leq +135^\circ\text{C}$	$\leq +135^\circ\text{C}$
T140°C	$\leq +140^\circ\text{C}$	$\leq +140^\circ\text{C}$

Example of gas class determination

Cleaning fluid temperature is 67°C and ambient temperature is 75°C.
Gas class = T5

ATEX/IECEx marking for the equipment SJ20A:



II 1G Ex h IIC 85°C...175°C Ga
II 1D Ex h IIC T85°C...T140°C Da

3.7.2 Air drive unit

The maximum surface temperature for the Air drive unit in operation is independent of the cleaning fluid temperature. The Air drive unit is only permitted to be used in an ambient temperature range of -20°C to +40°C.

ATEX marking for the equipment SJ20A - Air motor::



II 2G Ex h IIC T4 Gb
II 2D Ex h IIC T135°C Db

3.8 Quality system

The Alfa Laval Toftejorg SaniJet 20 is produced according to Alfa Laval Kolding's ISO 9001 International Standard certified quality system. All parts are made from certified material and all non-metal parts are made from FDA and USP Class VI approved materials.

4 Installation

Toftejorg SaniJet 20 Air driven

4.1 General description

The Alfa Laval Toftejorg SaniJet 20 is a tank cleaning machine intended for industrial use in closed tanks for processing storage and transportation. There is a broad range of application areas within pharmaceutical, food and chemical industries.

The Alfa Laval Toftejorg SaniJet 20 is a hygienic cleaning device of the rotary jet head type for permanent installation that provides a 360° indexed cleaning pattern. Provided it is installed in an upright position, the Alfa Laval Toftejorg SaniJet 20 is completely self-cleaning and self-draining, and it has an integrated self-cleaning down pipe (patent pending). The drive mechanism is located outside the tank or process equipment, leaving a minimum of parts to be submerged into the product. All product contact surfaces are AISI 316/316L, duplex SAF 2205, Ti, Hastelloy C22/C276 stainless steel and USP Class VI and FDA approved polymer materials such as PEEK, EPDM, Viton and FFKM.

No threads or screws have been used in the product contact areas.

The cleaning device is lubricated by the cleaning media. No oil, grease or other lubricants are used.

The Alfa Laval Toftejorg SaniJet 20 is available in media driven or air motor driven versions. The air motor driven version is equipped with a magnetic clutch providing a leakage-proof transmission and provide an effective drive for low flow machines in rough environments. The air motor has variable speed in order to adjust cleaning intensity. The media version is covered by Instruction Manual IM-TE91A792.

The Alfa Laval Toftejorg SaniJet 20 is designed for use in pharmaceutical, biotechnological, food and dairy processing applications. Tanks and vessels between 0.5-30 m³ (130-8,000 US gallons). The design makes the Alfa Laval Toftejorg SaniJet 20 especially well suited when processing high viscous, foaming or thixotropic products and in chemical processing applications, where product cross contamination is unacceptable and must be avoided.

For use in explosive hazard zones the ATEX/IECEx version can be used, provided it is installed according to safety instructions in local regulations.

4.2 Functioning

Alfa Laval Toftejorg SaniJet 20 consists of 3 main parts: The **Drive unit** with flow inlet and the Base housing placed outside the tank, and inside the tank: the **Down pipe** with the rotating Outer tube and the **Cleaner unit**.



The flow of the cleaning fluid passes from the inlet through the Base housing, through the Down pipe, into the Cleaner head and out through the Nozzles. The Outer tube of the Down pipe is rotably suspended on a Stationary shaft with a Ball bearing inside the Outer tube. The Drive mechanism rotates the Outer tube with the Cleaner unit around the vertical axis. Via a set of Bevel gears on the Stationary shaft and the Cleaner head, the Cleaner head with the Nozzles is simultaneously rotated around the horizontal axis in a fixed relation thus moving the nozzles and the jets 360° around in the tank making a pre-set indexed cleaning pattern.

The Alfa Laval Toftejorg SaniJet 20 utilises the patented “Golden Section” cleaning pattern. The distance between the tracks of the jets ensures an efficient removal of remaining product from the tank surface right from the beginning of the cleaning sequence, allowing for short cleaning time.

Example - 2 nozzle machine:

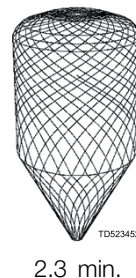
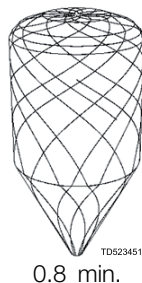

The time needed to perform a proper cleaning depends on type of soilage, distance, cleaning procedure and agent. For substances that are easily mobilised, i.e. are easy to remove, less than 1 min. could be sufficient while in cases of more heavy soilage (high viscous, sticky substances, etc.) a more dense pattern/longer time will be needed.

4 Installation

Tottejorg SaniJet 20 Air driven

Machine with external motor drive

The machine is driven by a gear motor mounted on top of the Inlet housing. Via a Magnetic clutch the rotation of the gear motor is transmitted from the outside through a closed wall to the Output shaft placed inside the Inlet housing. The Output shaft is in mesh with the Down pipe and rotates the Down pipe in the same way as in the media driven version.

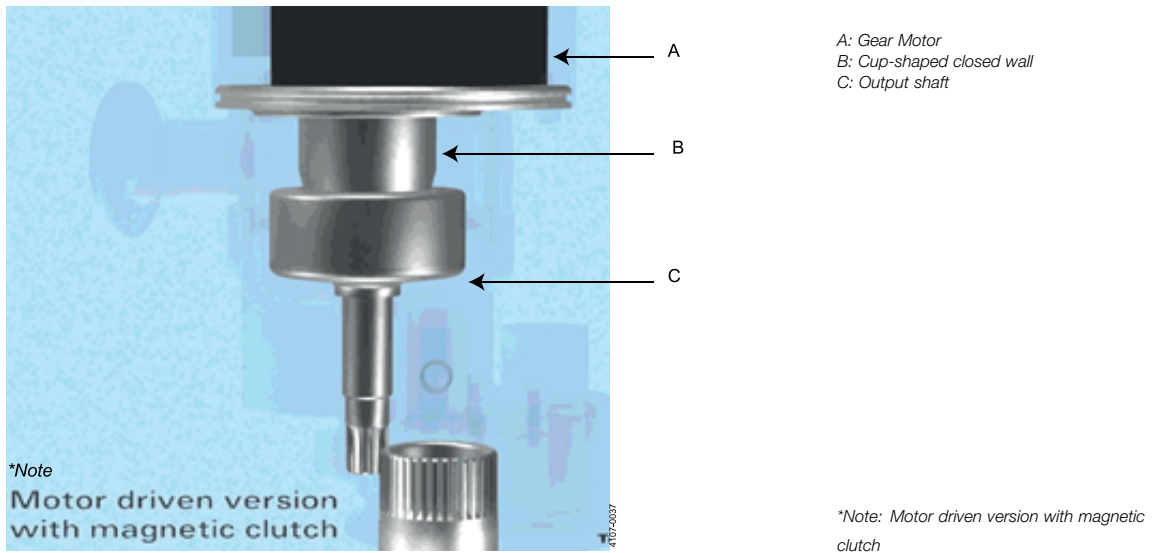

The output shaft of the gear motor is equipped with a Rotor with permanent magnets. The rotor is placed inside the cavity in the Motor flange, made by the cup protruding into the liquid chamber in the Inlet housing. The cup is welded to the motor flange as a hermetic sealed closed wall between the liquid chamber and the outside. The magnetic field from the permanent magnets is transferred through the wall, to a ring with permanent magnets inside the Output shaft, which is placed around the cup on the inside the liquid chamber.

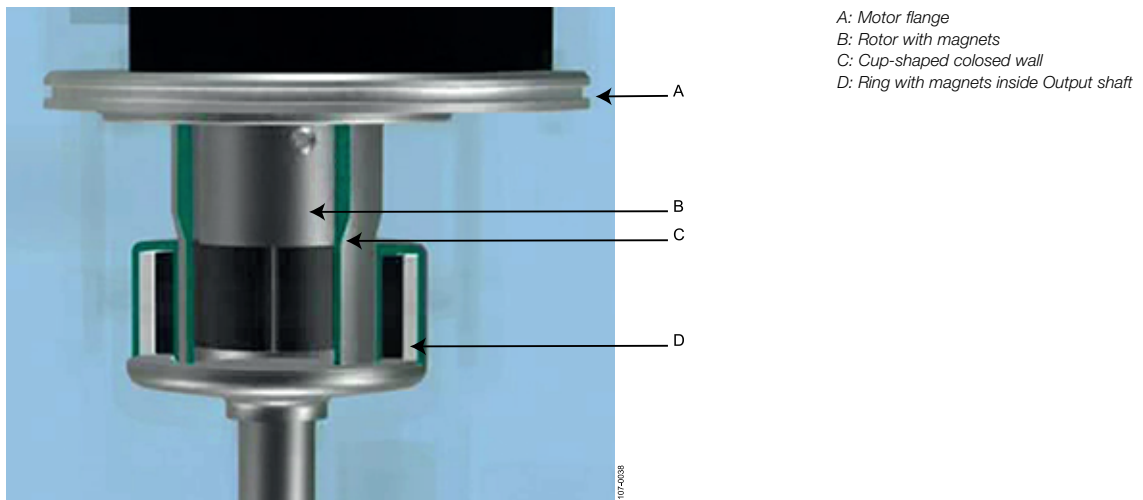

The machine with Air motor is equipped with a flow regulator to make the speed adjustable between approx. 3 and 14 RPM.

Self-cleaning

Apart from the main flow flushing the inside of the Base housing and the Down pipe, and thereafter forming the jets through the Nozzles, fluid is flushed through all internal cavities, through Bevel gear, Ball bearings and gabs between moving parts and is finally also used for cleaning of the outside surfaces of the machine. From the gab between the Base housing and the rotating Down pipe, a cleaning jet is directed against the Down pipe, thus loosening and removing product remains on the outside. A liquid film flushing all around the tube further assists by continuously transporting away loosened product remains. The front of the Cleaner head is flushed by a liquid flow from the gab between the Cleaner head and the Retaining ring.

In order to ensure a proper self-cleaning, the machine must be installed in an approx. **upright position** and the inlet pressure must be **min. 3 bar**. In the bottom of the Cleaner head, in the Retaining ring, the machine is equipped with a hole to ensure self-draining. This self-draining is only ensured, if the machine is installed in an **upright position**.

Cleaning Pattern, The Golden Section

The patented Golden Section cleaning pattern (EP-Patent No.: 0495883. US-Patent No.: 5,279.675) is unique in building up the pattern in an ultimate uniform way. The pattern starts very coarse and refines itself in a step-less way by laying out the tracks approximately in the middle between the two most distant tracks already made. This means that the jets always clean the areas containing most remaining product, and thereby remove as much deposit as possible in the shortest possible way.

In case a complete cleaning pattern is not required, it will be possible to reach the same cleaning level within half the time and by using half the amount of cleaning fluid compared to a traditional step-wise cleaning pattern. Furthermore, due to the uniform cleaning pattern, the cleaning can be stopped at any time, whereas with traditional non-uniform cleaning pattern this would not be advantageous. However, after the complete cleaning pattern has been established, the difference between the Golden Section and the traditional stepwise cleaning pattern is negligible.

Golden Section - Cleaning pattern

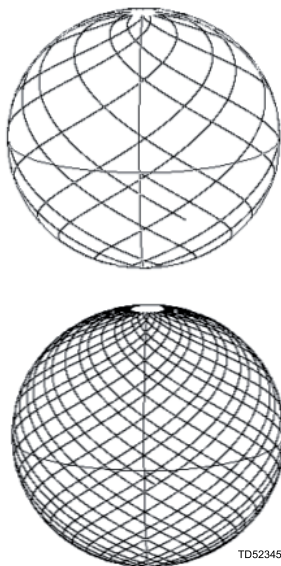

Traditional - Cleaning pattern

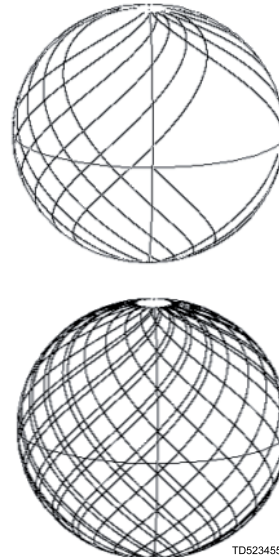

4 Installation

Tottejorg SaniJet 20 Air driven

4.3 Installation of Air Motor

Important information

Recommended inlet air pressure is not to exceed 6 bar (87) psi maximum. It is recommended to use an air filter and moisture trap on inlet air supply to avoid contamination being fed into air motor.

General information

The air motor is designed to be driven by compressed air and under no circumstances be driven with any other gases. Fluids, particles, solids or any substances mixed with air, particularly combustible substances likely to cause explosions, must not drive air motor.

Warning: Do not drive with flammable or explosive gases.



Warning: Air motor is designed for air only. Do not allow corrosive gases or particulate material to enter motor. Water vapor, oil-based contaminants, or other liquids must be filtered out.



Warning: Do not use a hammer or force coupling or drive pulley onto shaft when installing drive onto air motor. This causes end thrust that could damage air motor.



Note: Ambient temperature outside tank should not exceed +40°C (140°F)

Installation

Install a moisture trap and filter in air line ahead of motor. For efficiency of output and control of speed, use air lines of same size or in next pipe size larger than intake port of motor. As inlet line a $\varnothing 8/6$ tube should be used (customer supply). As standard, the drive unit is fitted with a hose connector $\varnothing 8$ on the blow-out line. It is possible to lead the exhaust out of the room with a hose and it is recommended in this context to use an adapter so that a $\varnothing 12$ tube or larger can be used for this. It is also possible to attach a silencer on the exhaust, but in this respect it should be borne in mind that a possible oil mist may contaminated surroundings in the room where it exhausted

Lubrication

The pneumatic oil used for lubrication must have a self-ignition temperature above 260°C and have a viscosity between 22 and 46 cst depending on the temperature of the motor operation (e.g. 40°C the viscosity of the oil shall be between 22 and 30 cst).

MODEC recommends that an automatic air line lubricator, be installed in air line just ahead of air motor. Lubricator should be adjusted to feed with 50mm³ of oil per m³ of air (1 drop = 15 mm³) (see table below).

At max power		At max speed	
Air cons. (l/min)	Lubrication (drops/min)	Air cons. (l/min)	Lubrication (drops/min)
290	2	360	2

Valve mini Kv	Max air flow (l/min)	Feeding pipe min. internal dia. (mm)	Connection min. internal dia. (mm)
20	1293	6	5

Lubrication is necessary for all internal moving parts. Excessive moisture in air line can cause rust formation in motor and might also cause ice to form in muffler due to expansion of air through motor. Moisture problem can be corrected by installing a moisture separator in line and also by installing an after-cooler between compressor and air receiver.

A lubricant filter (FRL) unit should be installed between upstream from the motor. Filtration should be 50 micron maximum.

Mounting

Warning:



Beware of any exposed and/or moveable parts. Proper guards should be in place to prevent personal and/or property damage.

4 Installation

Toftejorg SaniJet 20 Air driven

4.4 General safety and installation instructions

The Alfa Laval Toftejorg SaniJet 20 is designed to be installed in a vertical upright position.

It is recommended to install a filter with mesh size 250 µm (0,0001") in the supply line in order to avoid particles, scale etc. from clogging inside the machine. It is essential to avoid fine solid particles, such as fine sand, in the cleaning fluid as they will increase wear considerably. This is particular important in case of recirculation.

In order to prevent accidental leakage of cleaning fluid into the tank it is recommended to install a shut-off valve close to the machine inlet. This will also prevent back-flow of liquid from the tank through the machine in case the cleaner head is submerged and there is an over-pressure inside the tank. The installation and operation shall be made in such a way that the draining of the machine is ensured.

It is recommended that the fluid valve fitted is of a type that **prevents hydraulic shocks**, which may cause severe damage to the entire installation.

Before installation, all supply lines and valves must be thoroughly flushed to remove remains of welding electrodes, grinding dust, scale and other foreign matter.

During handling and installation handle the machine with care in order not to damage the fine surface finish of the machine.

The Alfa Laval Toftejorg SaniJet 20 machine has been tested in a test tank, according to Alfa Laval test procedures at the factory before shipping.

NOTE

Note: Do not try to turn Nozzle head by hand, since this may damage the Gear. Nozzle head can be turned by blowing air from an air pistol through the inlet connection of the media driven machine or the intake port of the air motor.

NOTE

The machine shall be installed in accordance with national regulations for safety and other relevant regulations and standards. In EU-countries the complete system must fulfil the EU-machine Directive and depending of application, the EU-Pressure Equipment Directive, the EU-ATEX/IECEx Directive and other relevant Directives and shall be CE-marked before it is set into operation.

Warning:



Precautions shall be made to prevent starting of the cleaning operation, while personnel are inside the tank or otherwise can be hit by jets from the nozzles.

For information on use in potential explosive atmospheres see paragraph 4.5 Specific conditions for safe use in accordance with ATEX/IECEx certification page 21.

4.5 Specific conditions for safe use in accordance with ATEX/IECEx certification

Directive 2014/34/EU

NOTE

Explosion protection type is constructional safety “c”.

Warning: Operated in a hazardous area

The unit may not be operated when steaming.

The unit may be operated in a hazardous area only when completely filled with cleaning fluid.

If a medium other than the cleaning fluid is passed through the equipment the unit may not be operated.

The fitted air driven motor, shall be placed outside the Zone 0/20 environment.

Warning: Operating guidance

The unit shall be operated in line with guidance provided by IEC/TS 60079-32-1 for tank cleaning.

Warning: Temperature class and ambient temperature range

The maximum surface temperature depends mainly on operating conditions which are the temperature of the cleaning fluid and ambient temperature.

The temperature class and ambient temperature range are shown in paragraph 3.7 ATEX/IECEx temperature class and code, page 12.

Warning: Max. permitted temperature

Cleaner unit when working:

The maximum permitted cleaning fluid temperature and ambient temperature is 90°C.

Cleaner unit when not working:

The maximum permitted ambient temperature is 140°C.

Drive unit when working:

The maximum permitted ambient temperature is 40°C.

Drive unit when not working:

The maximum permitted ambient temperature is 80°C.

Warning: Draining using compressed air

Draining using compressed air must not be done in ex classified zone.

Draining using compressed air is possible in non ex classified zones (see page 43).

Warning: Earthing

All metal and other conductive or dissipative material should be connected to earth with the exception of very small items.

For further information see IEC/TS 60079-32-1:2013 Explosive atmospheres – Part 32-1: Electrostatic hazards, guidance. With focus on clause 6.2.3, 7.2.1, 7.3, 7.9.2, 13.

4 Installation

Tottejorg SaniJet 20 Air driven

4.4 Specific conditions for safe use in accordance with ATEX/IECEx certification

Warning: Earthed when in use

The unit must be effectively earthed at all times when in use.



Warning: Max. permitted steaming temperature

The maximum permitted steam temperature through the machine and ambient temperature is 140°C.



Warning: Steaming tanks larger than 100 m³

Tanks with capacities larger than 100 m³ that could contain a flammable atmosphere should not be steam cleaned, as steam cleaning tanks produces an electrostatically charged mist. Tanks smaller than 100 m³ may be steam cleaned.

For further information see IEC/TS 60079-32-1:2013 Explosive atmospheres – Part 32-1: Electrostatic hazards, guidance. With focus on clause 7.10 and 8.5.



Tank size information

NOTE: The tank cleaning machine has been certified by accredited notified body and can operate in tanks having an enclosed volume up to 100 m³ as long as all ATEX/IECEx warnings in the instruction manual are complied with.

General guidelines for tanks larger than 100 m³:

Tanks larger than 100 m³ must not be steam cleaned – See guide IEC/TS 60079-32-1:2013 clause 7.10.5 and 8.5

To use the unit in tanks larger than 100m³ is possible under certain conditions.

It is necessary to know the current factors such as tank size, cleaning solvent and product.

Additives can be used in the cleaning solvent, or, for example, the tank can be filled with nitrogen. The basic guidelines are described in the guide IEC/TS 60079-32-1:2013.

It must be ensured that the equipollently bonding of all conductive metal objects is in accordance with national regulations for use.

The cleaning fluid conductivity must correspond to the products in the group “High conductivity”, cf. IEC/TS 60079-32-1:2013 clause 7.1 and 7.2.

High conductivity	> 10 000 pS/m
Medium conductivity	between $25 \times \epsilon_r$ pS/m and 10 000 pS/m
Low conductivity	< $25 \times \epsilon_r$ pS/m

For liquids with a dielectric constant of around 2, (e.g. hydrocarbons), these classifications reduce to:

High conductivity	> 10 000 pS/m
Medium conductivity	between 50 pS/m and 10 000 pS/m
Low conductivity	< 50 pS/m

Following a guidance document such as IEC/TS 60079-32-1:2013 to establish safe use of machinery and process is the users own responsibility and is not covered by the ATEX/IECEx certification for this unit except for tanks up to 100 m³. For further information see IEC/TS 60079-32-1:2013 Explosive atmospheres – Part 32-1: Electrostatic hazards, guidance with focus on clause 7.1.3, 7.1.4, 7.2.1, 7.2.4.

4.4 Specific conditions for safe use in accordance with ATEX/IECEx certification

Warning: Process generated electrostatic

The user must address the electrostatic hazards generated from the process of the equipment in accordance with guidance document IEC/TS 60079-32-1:2013.

Warning: Electrostatically charged liquid

Liquids can become electrostatically charged when they move relative to contacting solids or the spraying of liquids can also create a highly charged mist or spray. The liquid must be made electrically conductive by additives or otherwise.

For further information see IEC/TS 60079-32-1:2013 Explosive atmospheres – Part 32-1: Electrostatic hazards, guidance. With focus on clause 7.1.3, 7.1.4, 7.2.1, 7.2.4.

Warning: Appropriate cleaning fluid

The cleaning fluid should be appropriate for the application (e.g. so no chemical reaction can take place between the cleaning fluid and the residue of process fluid/powder/compound which can generate heat or a hybrid mixture).

Chemical reactions in Zone 20 - Hybrid mixtures:

End-user must ensure that the cleaning fluid used does not create a hybrid mixture according to IEC 60079-10-1:2015 Annex I.1 in connection with powder / dust residues in the tank in zone 20.

This should ensure that the atmosphere does not change to a classification that lies outside the machine's certified scope. When the machine is used for cleaning tanks containing potentially flammable dust atmospheres, and a potentially flammable fluid is used as the cleaning fluid then an assessment of the hybrid mixture shall be undertaken by the user, prior to operation.

For further information see IEC 60079-10-1:2015 Explosive atmospheres – Part 10-1: Classification of areas – Explosive gas atmospheres. With focus on clause 3.6.6 and Annex I – Hybrid mixtures.

Warning: Fluid pressure

The maximum permitted cleaning fluid pressure is 13 bar.

Warning: MODEC air motor drive media

MODEC air motors are designed to be operated by compressed air only. Do not drive with flammable or explosive gases.

Warning: MODEC air motor lubrication

MODEC air motors are designed to be operated by lubricated compressed air. The pneumatic oil used must have a self-ignition temperature above 260°C. The air motor must be lubricated with 50mm³ per m³ of air (1 drop = 15 mm³). The pneumatic oil used must have a viscosity between 22 and 46 cst depending on the temperature of the motor operation (e.g. 40°C the viscosity of the oil shall be between 22 and 30 cst).

In addition to the above mentioned precautions relating to the ATEX guidelines Directive 2014/34/EU the Safety Precautions on page 20 must be observed.

5 Operation

Tottejorg SaniJet 20 Air driven

5.1 Normal operation

Cleaning Media

Use only cleaning fluids, which are compatible with Stainless Steel AISI 316/316L, SAF2205, Ti, Hastelloy C22/C276, PEEK, EPDM, Viton and FFKM. Please note that PEEK is not resistant to concentrated sulfuric acid. Normal detergents, moderate solutions of acids and alkalis are acceptable as well as a number of solvents at ambient temperature during cleaning. Aggressive chemicals, excessive concentrations of chemicals at elevated temperatures as well as certain solvents and hydrochlorides should be avoided. If you are in doubt, contact your local Alfa Laval sales office.

Pressure

Avoid hydraulic shocks. Increase pressure gradually. Do not exceed 12 bar inlet pressure. Recommended inlet pressure: 5-8 bar (73 - 116 psi). High pressure in combination with high flow rate increase consumption of wear parts. High pressure also reduces the cleaning effect.

The machine is designed to stand up to 13 bar working pressure. This is normally not recommended but may be used for special purposes, where high pressure at close distance is preferred.

Temperature

The maximum recommended cleaning fluid temperature is 90°C. The maximum recommended steam temperature is 140°C. The maximum ambient temperature is 140°C.

See paragraph 4.5 Specific conditions for safe use in accordance with ATEX/IECEx certification (page 21).

After use cleaning

After use flush the machine with fresh water. Cleaning media should never allow to dry or settle in the system due to possible "salting out" or "scaling" of the cleaning media. If cleaning media contains volatile chloride solvents, it is recommended **not to flush with water** after use, as this might create hydrochloric acid.

5.2 Normal Operation of Air Motor

Never let the machine run dry without cleaning media except for short time under surveillance. It is recommended always to put on pressure with cleaning media before the air motor starts rotating. This will ensure proper cooling and lubrication of the bearings.

Warning:



Do not remove muffler during operation. Solid or liquid material exiting unit can cause eye or skin damage. Keep away from air stream. Always disconnect air supply before servicing.

Speed adjustment

The air motor provides adjustable rotation speed and makes it possible to optimise the cleaning time and fluid consumption to the actual cleaning job.

High rotation speed may be used in small tanks with easy to clean substances, whereas larger tanks or more difficult cleaning tasks require slower rotation for longer throw length or higher impact and wetting intensity. The correlation between rotation speed, throw length and cleaning time appears from the curves and the table on page ff.

The rotation speed is pre-set at the factory to approx. 8-12 RPM depending on the configuration. The rotation speed is adjusted on the Flow regulator (66) with a small screwdriver, see photo below.

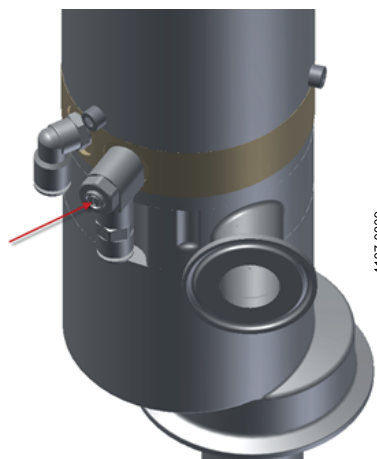

The speed can be approximately adjusted without cleaning media, however when cleaning with media under pressure the rotation speed will be slightly reduced. For fine adjustment the machine should be installed in the tank and run with cleaning media at the stipulated pressure in the closed tank.

To verify the rotation speed: record the time intervals between vertical jet impingements on the tank top. This can easily be detected from the sound pattern of the jets moving over the tank surface. Use the table on page ff to find time interval for the desired RPM-value.

Warning:



Do not allow air motor to "run free" at high speeds with no loads. Excessive internal heat build-up, loss of internal clearances and rapid motor damage will result.

5 Operation

Toftejorg SaniJet 20 Air driven

5.3 Safety Precautions

The machine is intended for use inside a tank only. As peak velocity of main jets reaches 40 m/s, Alfa Laval Toftejorg SaniJet 20 must not be operated in open air or when tank is open.

Warning:



Hot chemicals and steam under pressure may be used for cleaning and sterilising. Protect against scalding and burning. Never tamper with or try to open clamps or other connections while system is in operation. Make sure that system is de-pressurised and drained before disassembly.

The cleaning jets impinging the tank surface are a source of noise. Depending on pressure and distance to the tank walls, noise level may reach up to 85 dB.

Warning:



Tanks may contain poisonous/hazardous products or products which represent an environmental or safety risk. Never open tank and dismount the machine without checking previous tank contents and necessary precautions.

Warning:



Retaining screw on side of Base housing (17) must never be loosened, when machine is mounted in tank unless down pipe is supported and Pressure line is disconnected, as otherwise the complete Down pipe assembly will fall down.

Safety Precautions for Air Motor

Warning:



Do not remove muffler during operation. Solid or liquid material exiting unit can cause eye or skin damage. Keep away from air stream. Always disconnect air supply before servicing.

Warning:



Do not use kerosene or other combustible solvents for cleaning the inside of the motor during maintenance.

See also 3.7 ATEX/IECEX temperature class and code, page 12.

6.1 Preventive Maintenance

In order to keep your tank cleaning machine servicing you as an efficient tool in your tank cleaning operations, it is essential to maintain its high performance by following a simple preventive maintenance programme.

Good maintenance is careful and regular attention!

The following recommended preventive maintenance is based on tank cleaning machines working in average conditions. However, you will appreciate that a tank cleaning machine, which has a rough and dirty job to do, will need more frequent attention than one working in ideal conditions. We trust that you will adjust your maintenance programme to suit.

Handle machine with care. Take proper action to protect fine surfaces from being damaged.

Always use only proper tools. Use Toftejorg™ SaniJet 20 standard tool kit (page 58). If not stated otherwise never use unnecessary force (i.e. hammer or pry) components together or apart. Always perform all assembly/disassembly steps in the order described in this manual.

Never assemble components without previous cleaning. This is especially important at all mating surfaces.

Work in a clear well lighted work area.

6.2 Reserved rights for design changes of Alfa Laval equipment used in validated processes

Alfa Laval is continuously working on improving our equipment and services. In this improvement work Alfa Laval may for example change the design and material in our equipment. A change in the design will not necessarily entail a change of the specification and item no. for the equipment.

Alfa Laval reserves the right to change the design of Alfa Laval equipment without any notifications for improvements of our design.

If Equipment from Alfa Laval is used in connection with, for example, a validated plant, and an order for replacements is made, the design of the replacement may have been changed even if the specifications /item no. is the same as the existing installed and validated ones.

When ordering a replacement please contact Alfa Laval sales support in this matter before placing the order.

6 Maintenance

Tottejorg SaniJet 20 Air driven

6.3 Preventive Maintenance of Air Motor

General recommendations

- Air motor maintenance shall be performed by skilled operators, trained by MODEC or by our after sales service department.
- It is advisable to check and clean air motors every six months when used daily.
- In case of engine malfunction after a period of inactivity, insert a few oil drops into the air supply pipe.
- Always Unplug motor feeding connection before starting an operation of substitution, adjustment, maintenance or dismantling.
- After each maintenance operation, motors should be tested to check proper operation.
- Use only original replacement parts and elements for maintenance, lubrication and sealing.

Your motor has been delivered with permanent greasing, if required the reducer can be re-greased:

- old grease must be removed carefully.
- 50 to 70mL of grease 606 ORAPI CTDMEP 2 has to be distribute uniformly inside the reducer.

Quick diagnose

Symptoms	Causes	Actions
Rotation of the output shaft	<ol style="list-style-type: none">1. Insufficient air supply2. Too much load on the shaft3. Wrong seizing of internal components of motor4. Blades blocked	<ol style="list-style-type: none">1. Check the air source2. Check the air connection3. Check the load4. Pulse air in the inlet
Insufficient power, speed or torque	<ol style="list-style-type: none">1. Lack of pressure2. Lack of flow3. Outlet counter-pressure	<ol style="list-style-type: none">1. Check pressure2. Check flow3. Check that the muffler is adequately and properly fitted
Wrong rotation direction	<ol style="list-style-type: none">1. Wrong hose connection	<ol style="list-style-type: none">1. Reverse input and output2. Check the air connection

- If after all checks listed in this manual your motor is not working properly, please contact the "MODEC After Sales Services", www.modec.fr. www.modec.fr

Shutdown procedure

1. Turn off air intake supply and remove plumbing.
2. Remove air motor from connecting machinery.
3. Use clean, dry air at low pressure to "flush out" condensates, such as water.

Warning:



Solid or liquid material exiting unit can cause eye or skin damage. Keep away from air stream.

4. Re-lubricate air motor with a squirt of oil in chamber. Rotate shaft by hand several times.
5. Plug or cap each port.

Unit is ready for storage.

6.4 Service and repair of ATEX/IECEX certified machines

Warning:



All service and repair of ATEX/IECEX certified machines can be performed by Alfa Laval Kolding A/S, Denmark, or by an Alfa Laval service center approved by Alfa Laval Kolding A/S.

Changes to the machine are not allowed without approval by the person responsible for the ATEX/IECEX certification at Alfa Laval. If changes are made – or spare parts other than Alfa Laval original spare parts are used - the EC Type Examination certification (the ATEX/IECEX Directive) is no longer valid.

In order to ensure compliance with the ATEX/IECEX regulations and keep the machine ATEX/IECEX certification valid, the service or repair must be performed by an authorized person with knowledge of the ATEX/IECEX requirements and regulations. All spare parts must be original Alfa Laval spare parts and the repair or service must be done according to the instructions in this manual.

If a customer wishes to carry out service or repair himself, it is the responsibility of the repair shop to ensure that the ATEX/IECEX requirements are met in any way possible. After performing service or repair, the repair shop thus carries the full responsibility for traceability of all relevant documents in order to ensuring the retention of the ATEX/IECEX certification of the machine.

6 Maintenance

Tottejorg SaniJet 20 Air driven

6.5 Service and repair of machines ordered with Q-doc and with Q-doc + FAT-SAT

In order to ensure full traceability and to obtain full qualification and validation documentation, all service and repair of machines ordered with Q-doc (Equipment Documentation) and Q-doc + FAT-SAT (Qualification Documentation) should be handled and ordered in one of the 3 different ways described below:

1. Q-doc + FAT-SAT Service/Repair Order (Item no. TEREP-Q-doc):

(This maintenance order should be selected if the customer wishes to have Alfa Laval Kolding A/S to obtain full file log of all FAT (Factory Acceptance Test) documents for the Tank Cleaning Machine).

- Maintenance/Repair is carried out at Alfa Laval Kolding A/S and Q-doc + FAT-SAT Maintenance Log, FAT-SURFACE (if necessary), FAT-WELD (if necessary) and FAT-PERFORMANCE is performed. The FAT documents are stored in the Q-doc + FAT-SAT Maintenance Log as PDF-files.
- Q-doc (Equipment Documentation) for all steel spare parts are stored in the Q-doc + FAT-SAT Maintenance Log as PDF-files.
- The machine is returned to the customer incl. the Q-doc + FAT-SAT Log CD and hardcopy of all FAT documents, for further qualification (SAT: Site Acceptance Test) and validation (PV: Process Validation).
- Word and PDF documents are stored in the Alfa Laval Q-doc + FAT-SAT Maintenance Log folder.

2. Q-doc Spare Part Order (Item no.: TE24XXXX-90, TE24XXXX-91 or TE24XXXX-94)

(This maintenance order should be selected if the customer wishes to carry out service or repair. The customer or the repair shop thus carries the full responsibility for the full traceability of the material and FAT documentation for the Tank Cleaning Machine).

- The spare part is sent to the customer incl. Q-doc (Equipment Documentation) as hardcopy.

3. Q-doc + FAT-SAT Spare Part Order (Item no.: TE24XXXX-5X for Inner shaft (14), Outer pipe (12) and Inlet cap (61))

(This maintenance order should be selected if the customer wishes to carry out service or repair. The customer or the repair shop thus carries the full responsibility for the full traceability of the material and FAT documentation for the Tank Cleaning Machine).

- The spare part is sent to the customer incl. Q-doc (Equipment Documentation) incl. Weld-Log documentation (Inner shaft, Outer pipe) as hardcopy.
- This service information will not be recorded in the Alfa Laval Q-doc + FAT-SAT folder. The customer has to perform all Qualification tests and documentation (FAT, SAT, IQ & OQ) himself.

Contact local Alfa Laval service and support (see. www.alfalaval.com). Important information to give to Alfa Laval:

- Serial No.
- Q-doc maintenance order type:
 - Item no.: TEREP-Q-doc
 - or
 - Item no.: TE24XXXX-90, -91 or -94
- Item no.: TE24XXXX-5X (see page 44 for more information)

6.6 Every 300 working hours

1. Disassemble machine as described on the following pages.
2. Clean material build-up and deposits from internal parts with water or suitable chemical cleaner, possibly Scotch-brite, S-Ultrafine.
3. Check Bearing bushes (20 + 19) in Base housing by fitting Rotor outer (60) and check sideways movement. Replace if necessary. If bushes are worn they will allow Rotor outer to tilt and eventually it may seize up.
4. Check unrestricted rotation of Ball bearings. Inspect for build-up of foreign material in Ball rings (10 + 4) and Ball races. Balls must rotate freely in Ball rings.

Assemble machines as described in the following pages:

5. After fitting the Rotor outer (60), before mounting Motor drive unit, rotate down pipe and check unrestricted rotation.
6. Also check unrestricted rotation of Motor drive unit before mounting on machine.

Note: Timely replacement of bearings will prevent costly damage to the gear. However, all Bearing bushes, made from high performance plastic PEEK-material, are mounted with press-fit and should not be removed unless they need to be replaced.

In order to ensure current good hygiene it is recommended to replace all rubber seals at each service inspection.

Apart from the parts specifically mentioned above, all the remaining wear parts should regularly be inspected for wear. Wear parts are specified in the Reference Lists of Parts, pages ff.

6 Maintenance

Toftejorg SaniJet 20 Air driven

6.7 Cleaner Head Unit - dismantling and reassembling

Dismantling

1. Loosen Cleaner head unit (1, 2, 3, 4, 5, 6, 7) with Hook spanner (tool no. TE20B701). Insert carefully into holes in Retaining ring (3). Turn counter-clockwise and draw out Cleaner head unit. Never use Pipe wrench or any other tool than the Alfa Laval Toftejorg SaniJet 20 special Hook spanner, which is developed especially to protect the surface from being damaged.
2. Remove Seal ring (8).
3. Pull off Clip ring (6). Push out Pin (7).
4. Draw off Bevel gear (5) together with Ball ring (4) and Retaining ring (3).
5. If replacement is necessary, pull off Bearing bush (2) from Cleaner head (1). The Bearing bush should not be removed unless worn or damaged. Wear on this part will increase leakage flow around the front of the Cleaner head, and accordingly increase the total flow rate.

Reassembling

1. If necessary press new Bearing bush (2) fully home onto Cleaner head (1).
2. Mount Retaining ring (3), Ball ring (4) and Bevel gear (5) on Cleaner head (1).
3. Hold Cleaner head and turn Bevel gear to align the groove over the holes in the Cleaner head. Mount Pin (7).
4. Secure with Clip ring (6) over Pin (7). Check that Pin with Clip ring can move axially.
5. Hold Retaining ring (3) and check free rotation of Cleaner head unit.
6. Insert Seal ring (8) into Cleaner house on Outer tube. Make sure that it is fitted correctly into recess.
7. Insert Cleaner head unit (1, 2, 3, 4, 5, 6, 7) in Outer tube. Correct mounting is made foolproof: Drain hole in Retaining ring must be at the lowest point. Tighten with Hook spanner (tool no. TE20B701).

Warning:



It is important that Seal ring is fitted correctly and that Retaining ring is tightened fully home against "stop". Check that assembly is firmly held in position. If assembly feels loose, replace Seal ring.

6.8 Base Unit - Dismantling and Reassembling

Dismantling of Outer tube

In order to dismantle the parts in the Outer tube, it is necessary first to release the Inner shaft (14).

Warning:



Retaining screw on side of Base housing (16) must never be loosened, when machine is mounted in tank unless down pipe is supported and Pressure line is disconnected, as otherwise the complete Down pipe assembly will fall down.

1. Remove Retaining screw (17). Loosen and unscrew with a M10 Hex key (Allen key). Pull out Outer tube (12) together with Inner shaft (14) from Base housing (16).
2. Turn Outer tube upside down. Hold Bevel gear (9) and push Inner shaft (14) approx. 5 mm into Outer tube. Then rotate Inner shaft ¼ revolution, in order for pin in the shaft to pass through grooves in Bevel gear. Remove Bevel gear (9) and Ball ring (10).
3. Rotate Inner shaft to pass grooves in Ball race (11) and pull it out. Tip out Ball race from Outer tube (12).
4. If it is necessary to replace Bearing ring (13) on Outer tube, pull it off. The Bearing ring should not be removed unless worn or damaged. Wear on this part will increase leakage around Down pipe and accordingly increase total flow rate. It is recommended to replace if diameter is below $\varnothing 38.7$ mm. Diameter must never be below $\varnothing 38.5$ mm.
5. Remove Plain seal (15) from Inner shaft (14).
6. If necessary, replace Bearing bush (20 and 19) in Base housing (16).

Reassembling of Outer tube

1. Mount Plain seal (15) on Inner shaft (14).
2. Turn Outer tube (12) upside down. Fit Ball race (11) into Outer tube. Make sure that it is correctly placed in recess.
3. Mount Inner shaft (14) from below into the Outer tube. Hold against Ball race (11) and fit Inner shaft pin through axial grooves. Place Ball ring (10) and Bevel gear (9) over Inner shaft on top of the Ball race (11). Hold Bevel gear, rotate Inner shaft and draw back to fit pin into groove in the end face of the Bevel gear.
4. Place Base housing (16) upside down. Fit upper end of Inner shaft into Base housing. By pressing at the lower end of Inner shaft push the entire assembly into Base housing. Tighten with Retaining screw (17).

Alfa Laval Toftejorg SaniJet 20 (4") is as a standard prepared for monitoring by a Rotacheck Sensor (see Rotacheck System). A Plug (22) is fitted in the Base housing in the opening designed for the Rotacheck sensor.

Dismantling of Plug or Rotacheck Sensor

1. Remove Screws (24). Loosen and unscrew with a Socket wrench (tool no. TE462A).
2. Remove Bracket (23).
3. Press up Plug/Rotacheck (22). Remove O-ring (21).

Reassembling of Plug or Rotacheck Sensor

1. Insert O-ring (21) in hole for Rotacheck on Base housing (16). Make sure that it is fitted correctly into O-ring groove inside hole. Insert Plug/Rotacheck (22).
2. Place Bracket (23) over Plug/Rotacheck.
3. Mount and tighten Screws (24) with Socket wrench (tool no. TE462A).

6 Maintenance

Toftejorg SaniJet 20 Air driven

6.9 Air Motor Drive Unit - dismantling and reassembling

Dismantling

1. Push the ring on the push-in fittings and release the compressed air tubes.
2. Remove the 3 pcs Screws (80) and take off the Motor cover (81).
3. Remove the 4 pcs M5 Screws (73) holding the Air motor Drive unit. Loosen and unscrew with a Hex key.
4. The complete Air motor Drive unit can now be removed and taken to the work shop for inspection and maintenance (see page 28).
5. For dismantling the air motor from the motor flange (68) first push out the Tubular rivet (63) and take off the Rotor inner (62). Remove the 2 Screws (75) and take off the air motor.

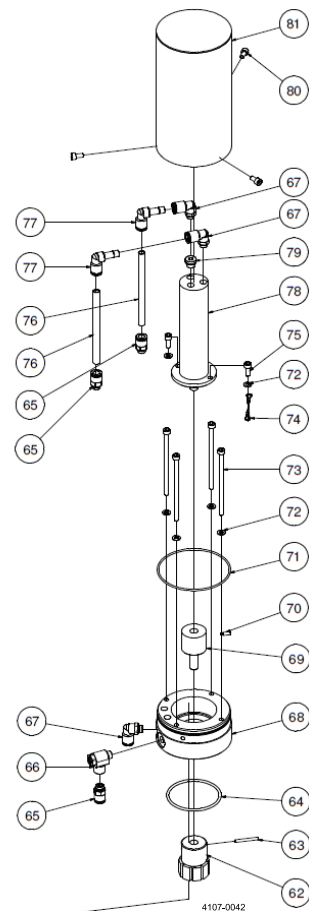
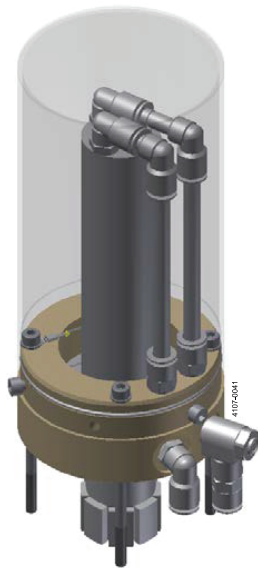

Reassembling

Reassembling is done in the reverse order.

Mount and tighten Screws (73) with Hex key. Tighten crosswise. Torque: 3-4 Nm

Warning:



Be careful when reinserting the Rotor with magnets into the cavity in the Motor flange (59). Hold Air motor Drive unit firmly and insert slowly. A strong magnetic field is present, which could pull the unit down or to one of the sides and damage the magnets.

Further dismantling

1. Lift off the Motor flange (59).
2. Remove Gasket (18) and lift off Inlet housing (61).
3. Withdraw Rotor Outer (60).
4. Remove Gasket (18) from Base housing (16).

Further reassembling

Before reassembly make sure that all parts are clean without deposits or build-up of foreign matter.

1. Insert Gasket (18) in top of Base housing (16).
2. Insert the Rotor outer (60). Check free rotation.
3. Replace Inlet housing (61) on Gasket (18) in Base housing (16).
4. Mount Gaskets (18) into Inlet housing (61).

6.10 Rotacheck System

The Rotacheck System is an ex-proof system, designed for monitoring the operation of the tank cleaning machine. The Sensor is supplied from a special Relay. The Sensor will send a signal to the Relay each time it is hit by a jet from the rotating tank cleaning machine, thus providing verification that the machine is rotating, of the rotation speed, and that the nozzles are not blocked. To install Rotacheck Sensor simply replace Plug (22) with Rotacheck Sensor TE52E067. For further information see PD Leaflet and instruction manual for Rotacheck system.

7 Trouble shooting guide

Tottejorg SaniJet 20 Air driven

Slow rotation or failure of machine to rotate

Possible Causes	Fault finding
No or insufficient liquid flow	<p>a). Check if supply valve is fully open. b). Check if inlet pressure to machine is correct. c). Check supply line/filter for restrictions/clogging. d). Remove Inlet cap (see page 32) and check for clogging in Impeller area. e). Remove Gear ring and Output shaft (see page 32) and check for clogging in Base housing. f). Remove Cleaner head (see page 32) and check Nozzles and Cleaner head for clogging. If blocked, carefully clean without damaging Nozzles vanes and Nozzle tip. Use air pistol. g) Inspect Bevel gear, Ball ring and Bevel gear inside Outer tube (see page 33). If necessary, remove parts and clean. If large particles repeatedly get jammed in the machine, install filter or reduce mesh size of installed filter in supply line.</p>
Foreign material or material build-up	<p>With air pistol blow air through inlet and check that machine rotates evenly. If any resistance is recognised, disassemble machine in order to localise the cause. Remove Turbine shaft with Impeller and Planet gear assembly (see page 32) and remove foreign material. Remove Turbine shaft with Impeller (see page 32) and clean Bearings. Remove foreign material from Planet wheel and Internal gears. Check rotation of Planet wheel. If restriction is recognised, disassemble Planet gear assembly (see page 32) and remove material build up, especially on Shaft and hole in Planet wheel. Remove Planet gear assembly (see page 32). Turn Down pipe and check unrestricted rotation. Remove Gear ring and Output shaft. Remove foreign material/material build-up on Output shaft, in holes and Bushes in Base housing. Rotate again Down pipe. It must rotate freely without any restriction. If not, remove Cleaner unit (see page 33). Clean out any foreign material and material build-up inside Cleaner head in the bottom of the Outer tube. Hold Retaining ring and rotate Cleaner head. If any restriction is recognised, disassemble Cleaner unit and clean all parts. Balls in ball ring must rotate freely. If Down pipe still does not rotate freely without any restriction, it must be disassembled. Clean opening in bottom of Base housing and Bearing ring on Outer tube. Remove Bevel gear, Ball ring and Ball race inside Outer tube and clean parts. Balls in Ball ring must rotate freely without any restriction.</p>
Wear	
a) Slide bearings	See page 27 ff.
b) Bearings for Turbine shaft	See page 27 ff.
c) Planet wheels	See page 27 ff.
d) Shafts for Planet wheels	Check clearance of Planet wheels on Shafts. Transverse movement should not exceed 0.3 mm.
e) Turbine shaft	Check clearance in Planet gear, Bearing bush and Bearings for Turbine shaft. Transverse movement should not exceed 0.3 mm. Also inspect teeth for wear.
Mechanical defects	
a) Planet wheels. Teeth broken	Replace Planet wheel.
b) Planet wheel can not rotate on Shafts/ Shafts bent	Replace Shafts for Planet wheels.
c) Damaged teeth on Bevel gear	Inspect teeth on Bevel gear for deformation. Mount Cleaner Unit in Outer tube (See page 33). Remove Planet gear. Hold Base housing and rotate Down pipe to check that Bevel gears can work together. If damaged: Replace Bevel gears.

Performance Data for Alfa Laval Toftejorg SaniJet 20 Air Driven

Weight of machine:	11.7 kg (25.8 lbs)
Working pressure:	3-13 bar (45-185 psi)
Recommended media pressure:	5-8 bar (75-116 psi)
Working temperature (Cleaning unit):	-20°C to +90°C (-4°F to +194°F) (cleaning fluid and ambient)
Max. temperature inside tank (Cleaning unit):	+140°C (284°F) (when not operating)
Working ambient temperature (Drive unit):	-20°C to +40°C (-4°F to +104°F) (ambient)
Max. air pressure (Drive unit):	6 bar (87 psi)
Max. ambient temp. f. air motor:	+40°C (104°F)
Effective throw length:	1.0-5 m (3-16 ft)
Materials:	Stainless Steel: AISI 304/316/316L, SAF 2205, Ti, Hastelloy C22/C276, MS-nickled
	Sealing: EPDM, Viton, FFKM. FDA-approved 21 CFR §177 and USP Class VI
	Polymers: PEEK, FDA-approved 21 CFR §177 and USP Class VI
Surface finish:	Product contact surfaces: Ra = 0.8 µm – except weldings
Improved surface finish:	0.5 µm Ra internal/external media contact parts - 0.8 µmRa non media contact parts.
	Note: Certain Exception applies
Lubricant:	Machine: See page 18
	Air motor: See page 18

Principal dimensions in mm

Inlet connection: 1" Clamp ISO2852

Tank connection: 4" Clamp ISO2852

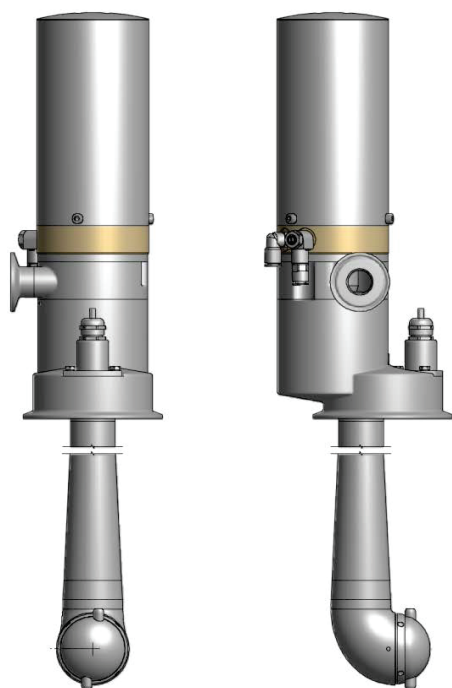

For portable installation or installation through long "nozzles",
4" (100 mm) version is recommended

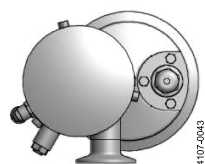
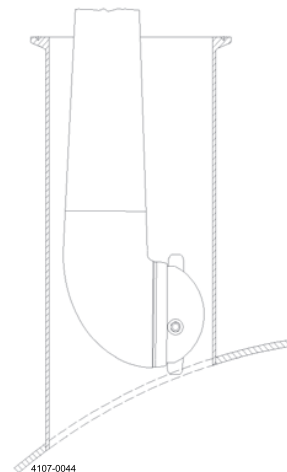

8 Technical data

Toftejorg SaniJet 20 Air driven

Principal dimensions in mm

Inlet connection: 1" Clamp ISO2852

Tank connection: 3" Clamp ISO2852

For permanent installation machine can pass through 3" clamp of max. length 50 mm:

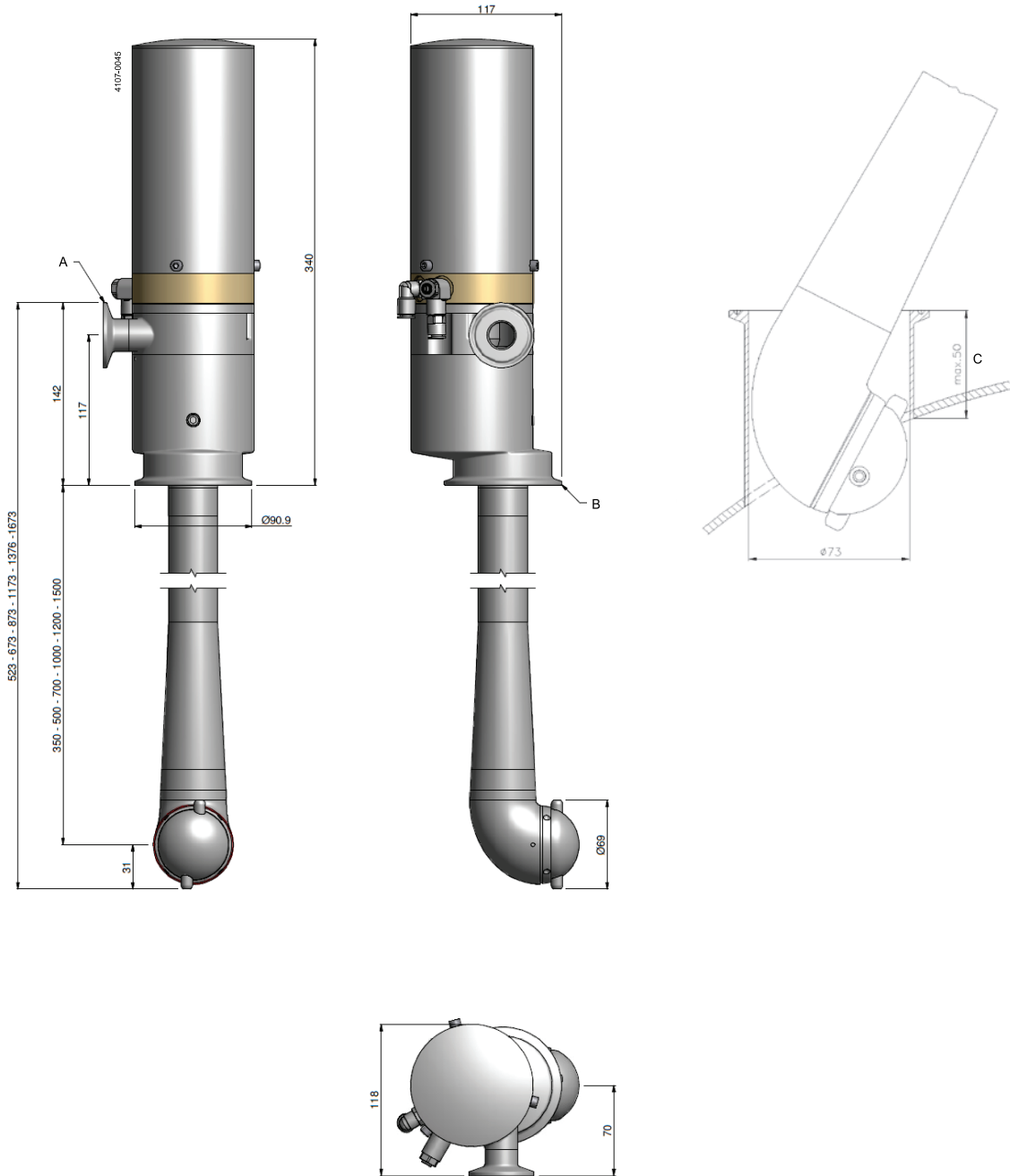

A: 1" Clamp ISO2852	B: 3" Clamp ISO2852	C: Max. 50 mm
---------------------	---------------------	---------------

Performance data for Alfa Laval Toftejorg SaniJet 20 air Driven

Flow rate

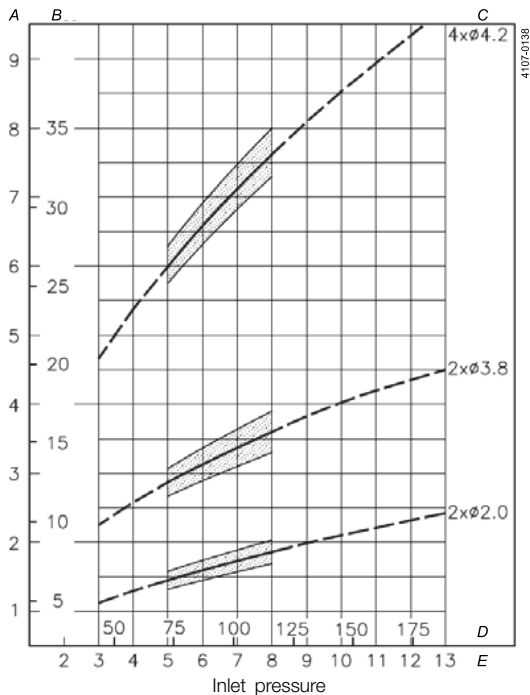

A: m³/h. B: USgpm. C: Nozzles mm. D: psi. E: bar

Throw length

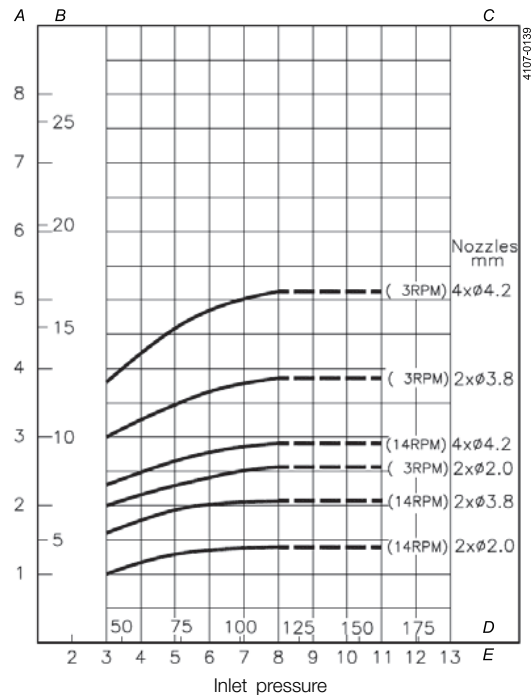

A: m. B: ft. C: Nozzles mm. D: psi. E: bar

Time between vertical jet impingements

Down pipe RPM	2 Nozzles	4 Nozzles	Cleaning time complete pattern
3	14.5 sec	7.2 sec	18.4 min
4	10.9 sec	5.4 sec	13.8 min
5	8.7 sec	4.3 sec	11.0 min
6	7.2 sec	3.6 sec	9.2 min
7	6.2 sec	3.1 sec	7.9 min
8	5.4 sec	2.7 sec	6.9 min
9	4.8 sec	2.4 sec	6.1 min
10	4.3 sec	2.2 sec	5.5 min
11	3.9 sec	2.0 sec	5.0 min
12	3.6 sec	1.8 sec	4.6 min
13	3.3 sec	1.7 sec	4.2 min
14	3.1 sec	1.6 sec	3.9 min

Note:

Effective throw length varies depending on rotation speed, jet transverse speed over surface, substance to be removed, cleaning procedure and agent.

The inlet pressure has been taken immediately before the machine inlet. In order to achieve the performance indicated in the curves, the pressure drop in the supply lines between pump and machine must be taken into consideration.

8 Technical data

Toftejorg SaniJet 20 Air driven

Performance Data for Alfa Laval Toftejorg SaniJet 20 Air Driven

Air supply pressure:	Max. 6 bar (87 psi)
Air quality:	Clean, filtered max. 50 µm Dry, dew point max. 5°C
Air consumption at max. speed:	6l/sec (22 m ³ /h) ~ 95 Usgpm
Adjustable speed:	3-14 RPM
Cleaning time:	4-18 min (adjustable)

This manual covers the product programme for Alfa Laval Toftejorg SaniJet 20 Air Driven. For information on Alfa Laval Toftejorg SaniJet 20 Media Driven please refer to Instruction Manual ESE01819

9.1 Standard configurations

Air Driven: Alfa Laval Toftejorg SaniJet 20 (3" connection)

Standard (EPDM as standard)			
Length	2 x ø2.0 mm	2 x ø3.8 mm	4 x ø4.2 mm
500 mm	TE24B100	TE24B120	TE24B160
350 mm	TE24B101	TE24B121	TE24B161
700 mm	TE24B102	TE24B122	TE24B162
1000 mm	TE24B104	TE24B124	TE24B164
1200 mm	TE24B106	TE24B126	TE24B166
1500 mm	TE24B108	TE24B128	TE24B168

Hastelloy (FFKM as standard)			
Length	2 x ø2.0 mm	2 x ø3.8 mm	4 x ø4.2 mm
500 mm	TE24C100	TE24C120	TE24C160
350 mm	TE24C101	TE24C121	TE24C161
700 mm	TE24C102	TE24C122	TE24C162
1000 mm	TE24C104	TE24C124	TE24C164
1200 mm	TE24C106	TE24C126	TE24C166
1500 mm	TE24C108	TE24C128	TE24C168

Improved surface finish* (EPDM as standard)			
Length	2 x ø2.0 mm	2 x ø3.8 mm	4 x ø4.2 mm
500 mm	TE24E100	TE24E120	TE24E160
350 mm	TE24E101	TE24E121	TE24E161
700 mm	TE24E102	TE24E122	TE24E162
1000 mm	TE24E104	TE24E124	TE24E164
1200 mm	TE24E106	TE24E126	TE24E166
1500 mm	TE24E108	TE24E128	TE24E168

Improved surface finish* and Hastelloy C22 (FFKM as standard)			
Length	2 x ø2.0 mm	2 x ø3.8 mm	4 x ø4.2 mm
500 mm	TE24D100	TE24D120	TE24D160
350 mm	TE24D101	TE24D121	TE24D161
700 mm	TE24D102	TE24D122	TE24D162
1000 mm	TE24D104	TE24D124	TE24D164
1200 mm	TE24D106	TE24D126	TE24D166
1500 mm	TE24D108	TE24D128	TE24D168

* Surface finish: 0.5 µm Ra internal/external media contact parts. 0.8 µm non media contact parts. Passivated. Note: Nominal Surface Finish

9 Product programme

This manual covers the product programme for Alfa Laval Toftejorg SaniJet 20 Air Driven. For information on Alfa Laval Toftejorg SaniJet 20 Media Driven please refer to Instruction Manual ESE01819

Air Driven: Alfa Laval Toftejorg SaniJet 20 (4" connection)

Standard (EPDM as standard)			
Length	2 x \varnothing 2.0 mm	2 x \varnothing 3.8 mm	4 x \varnothing 4.2 mm
500 mm	TE24G100	TE24G120	TE24G160
350 mm	TE24G101	TE24G121	TE24G161
700 mm	TE24G102	TE24G122	TE24G162
1000 mm	TE24G104	TE24G124	TE24G164
1200 mm	TE24G106	TE24G126	TE24G166
1500 mm	TE24G108	TE24G128	TE24G168

Hastelloy (FFKM as standard)			
Length	2 x \varnothing 2.0 mm	2 x \varnothing 3.8 mm	4 x \varnothing 4.2 mm
500 mm	TE24H100	TE24H120	TE24H160
350 mm	TE24H101	TE24H121	TE24H161
700 mm	TE24H102	TE24H122	TE24H162
1000 mm	TE24H104	TE24H124	TE24H164
1200 mm	TE24H106	TE24H126	TE24H166
1500 mm	TE24H108	TE24H128	TE24H168

Improved surface finish* (EPDM as standard)			
Length	2 x \varnothing 2.0 mm	2 x \varnothing 3.8 mm	4 x \varnothing 4.2 mm
500 mm	TE24F100	TE24F120	TE24F160
350 mm	TE24F101	TE24F121	TE24F161
700 mm	TE24F102	TE24F122	TE24F162
1000 mm	TE24F104	TE24F124	TE24F164
1200 mm	TE24F106	TE24F126	TE24F166
1500 mm	TE24F108	TE24F128	TE24F168

Improved surface finish* and Hastelloy C22 (FFKM as standard)			
Length	2 x \varnothing 2.0 mm	2 x \varnothing 3.8 mm	4 x \varnothing 4.2 mm
500 mm	TE24J100	TE24J120	TE24J160
350 mm	TE24J101	TE24J121	TE24J161
700 mm	TE24J102	TE24J122	TE24J162
1000 mm	TE24J104	TE24J124	TE24J164
1200 mm	TE24J106	TE24J126	TE24J166
1500 mm	TE24J108	TE24J128	TE24J168

* Surface finish: 0.5 μ m Ra internal/external media contact parts. 0.8 μ m non media contact parts.
Passivated. Note: Nominal Surface Finish



The item number must always be included with an add-on extension of **-XX**. (e.g. TE24G102-90)

9 Product programme

This manual covers the product programme for Alfa Laval Toftejorg SaniJet 20 Air Driven. For information on Alfa Laval Toftejorg SaniJet 20 Media Driven please refer to Instruction Manual ESE01819

9.2 Available add-ons

For: TE24 B XXX, TE24 E XXX, TE24 G XXX, TE24 F XXX	For: TE24 H XXX, TE24 C XXX, TE24 J XXX, TE24 D XXX
-0X Standard	-0X Standard
-5X Q-doc + FAT-SAT	-5X Q-doc + FAT-SAT
-6X Q-doc + FAT-SAT + ATEX	-6X Q-doc + FAT-SAT + ATEX
-7X ATEX	-7X ATEX
-8X Q-doc + ATEX	-8X Q-doc + ATEX
-9X Q-doc	-9X Q-doc
-X0 EPDM (Standard)	-X4 FFKM (Standard)
-X1 FPM (Viton)	
-X4 FFKM	

Explanation to Add-ons		
<p>Q-doc (Equipment Documentation)</p>		<p>Equipment Documentation includes:</p> <ul style="list-style-type: none"> - EN 1935/2004 DoC - EN 10204 type 3.1 inspection Certificate and DoC - FDA DoC - GMP EC 2023/2006 DoC - EU 10/2011 DoC - ADI DoC - QC DoC
<p>Q-doc + FAT-SAT (Qualification Documentation)</p>		<p>Qualification Documentation includes:</p> <ul style="list-style-type: none"> - RS, Requirement Specification - DS, Design Specification incl. Traceability Matrix - FAT, Factory Acceptance Test incl. IQ & OQ - SAT, Site Acceptance Test Protocol incl. IQ & OQ for End-User Execution - Q-doc
<p>ATEX/IECEX</p>		<p>ATEX approved machine for use in explosive atmospheres. Media/Air driven: Category 1 for installation in zone 0/20 in accordance with Directive 2014/34/EU II 1G Ex h IIC 85°C...175°C Ga II 1D Ex h IIC T85°C...T140°C Da Air motor unit: Category 2 for installation in zone 1/21 in accordance with Directive 2014/354/EU II 2G Ex h IIC T4 Gb II 2D Ex h IIC T135°C Db</p>

9 Product programme

This manual covers the product programme for Alfa Laval Toftebjerg SaniJet 20 Air Driven. For information on Alfa Laval Toftebjerg SaniJet 20 Media Driven please refer to Instruction Manual ESE01819

9.3 Available add-ons for spare parts

Item no.	Description
TE2XXXXX-90 or TE2XXXXX-91 or TE2XXXXX-94	Q-doc including - EN 1935/2004 DoC - EN 10204 type 3.1 inspection Certificate and DoC - FDA DoC - GMP EC 2023/2006 DoC - EU 10/2011 DoC - USP Class VI DoC - ADI DoC - QC DoC
TE2XXXXX-50 or TE2XXXXX-51 or TE2XXXXX-54 Inner shaft (14) or Outer tube (12) or Inlet cap (61) only	Q-doc + FAT-SAT including - Q-doc •Weld-Log documentation (if necessary) as hardcopy

9.4 Accessories

Clamp Coupling Parts

Item no.	Description
TE9611-31-019-0	Clamp welding liner 1"
TE9611-99-1358	Gasket EPDM f. 1" Clamp coupling
TE211053	Clamp ring 1"
TE9611-31-023-0	Clamp welding liner 3"
TE9611-99-1362	Gasket EPDM f. 3" Clamp coupling
TE211056	Clamp ring 3"
TE9611-31-024-0	Clamp welding liner 4"
TE9611-99-1363	Gasket EPDM f. 4" Clamp coupling
TE211057	Clamp ring 4"

Monitoring

An electronic system with rotation sensor to validate 360° coverage can be included:

TE52E067 Rotacheck Sensor \varnothing 27 mm
TE52E058 Rotacheck Relay

For further information see page 35.

10.1 Toftejorg SaniJet 20, Air Driven (EPDM as standard)

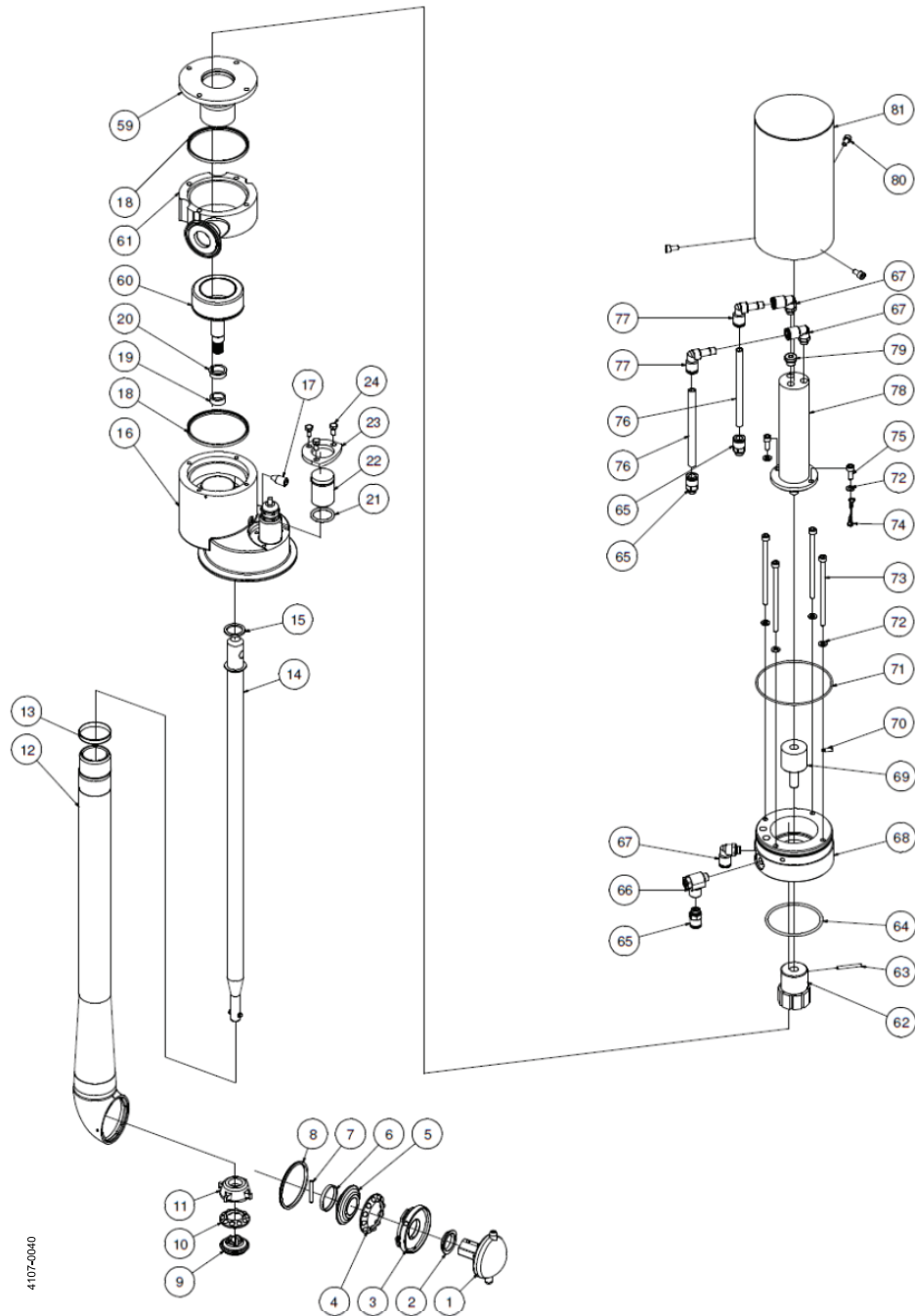

4107-0040

10 Parts drawings and lists, service kits and tools

Toftejorg SaniJet 20 Air driven

Parts list

Pos.	Qty	Denomination
1	1	Cleaner head
2	1	Bearing bush
3	1	Retaining ring
4	1	Ball ring N
5	1	Bevel gear
6	1	Clip ring
7	1	Pin
8	1	Seal ring H
9	1	Bevel gear
10	1	Ball ring
11	1	Ball race
12	1	Outer tube
13	1	Bearing ring
14	1	Inner shaft
15	1	Plain seal
16	1	Base housing
17	1	Retaining screw
18	2	Gasket
19	1	Bearing bush
20	1	Bearing bush
21	1	O-ring
22	1	Plug
23	1	Bracket
24	3	Screw
59	1	Motor flange welded A
60	1	Rotor outer complete
61	1	Inlet housing 1 Tri-clamp
62	1	Rotor inner w. magnets
63	1	Tubular rivet
64	1	O-ring
65	3	Straight connector
66	1	Flow control valve
67	3	L-connector
68	1	Flange for air motor

Service kits

Denomination	Item no.
Service kits	
Service kit in EPDM for Toftejorg SaniJet 20 air driven version	TE20B295
Service kit in VITON for Toftejorg SaniJet 20 air driven version	TE20B294
Service kit in PERLAST for Toftejorg SaniJet 20 air driven version	TE20C295

10 Parts drawings and lists, service kits and tools

Tottejorg SaniJet 20 Air driven

Parts marked with ● are included in the Service Kit EPDM: TE20B295

Parts marked with ✧ are included in the Service kit VITON: TE20B294

Parts marked with ○ are included in the Service kit PERLAST: TE20C295

Please note that some of the polymer parts are in PEEK, which is not resistant to concentrated sulfuric acid.

Configuration according to delivery note/order.

The machine can be delivered with ATEX/IECEX certification.

Please refer to the Spare Part Manual for information on item numbers and materials. The Spare Part Manual is available from the online Alfa Laval product catalogue Anytime or the Close at hand spare part catalogue.

10 Parts drawings and lists, service kits and tools

Toftejorg SaniJet 20 Air driven

Parts list			Service kits	
Pos.	Qty	Denomination	Denomination	Item no.
1	1	Cleaner head	Service kits	
2	1	Bearing bush	Service kit in EPDM for Toftejorg SaniJet 20 air driven version	TE20B295
3	1	Retaining ring	Service kit in VITON for Toftejorg SaniJet 20 air driven version	TE20B294
4	1	Ball ring N	Service kit in PERLAST for Toftejorg SaniJet 20 air driven version	TE20C295
5	1	Bevel gear		
6	1	Clip ring		
7	1	Pin		
8	1	Seal ring H		
9	1	Bevel gear		
10	1	Ball ring		
11	1	Ball race		
12	1	Outer tube		
13	1	Bearing ring		
14	1	Inner shaft,		
15	1	Plain seal		
16	1	Base housing		
17	1	Retaining screw		
18	2	Gasket		
19	1	Bearing bush		
21	1	O-ring		
22	1	Plug		
23	1	Bracket		
24	3	Screw		
59	1	Motor flange welded A		
60	1	Rotor outer complete		
61	1	Inlet housing 1 Tri-clamp		
62	1	Rotor inner w. magnets		
63	1	Tubular rivet		
64	1	O-ring		
65	3	Straight connector		
66	1	Flow control valve		
67	3	L-connector		
68	1	Flange for air motor		
69	1	Adapter for air motor		

10 Parts drawings and lists, service kits and tools

Toftejorg SaniJet 20 Air driven

Parts marked with ● are included in the Service Kit EPDM: TE20B295

Parts marked with ✧ are included in the Service kit VITON: TE20B294

Parts marked with ○ are included in the Service kit PERLAST: TE20C295

Please note that some of the polymer parts are in PEEK, which is not resistant to concentrated sulfuric acid.

Configuration according to delivery note/order.

The machine can be delivered with ATEX/IECEX certification.

Please refer to the Spare Part Manual for information on item numbers and materials. The Spare Part Manual is available from the online Alfa Laval product catalogue Anytime or the Close at hand spare part catalogue.

10.3 Toftejorg SaniJet 20 Air Driven Hastelloy (FFKM as standard)

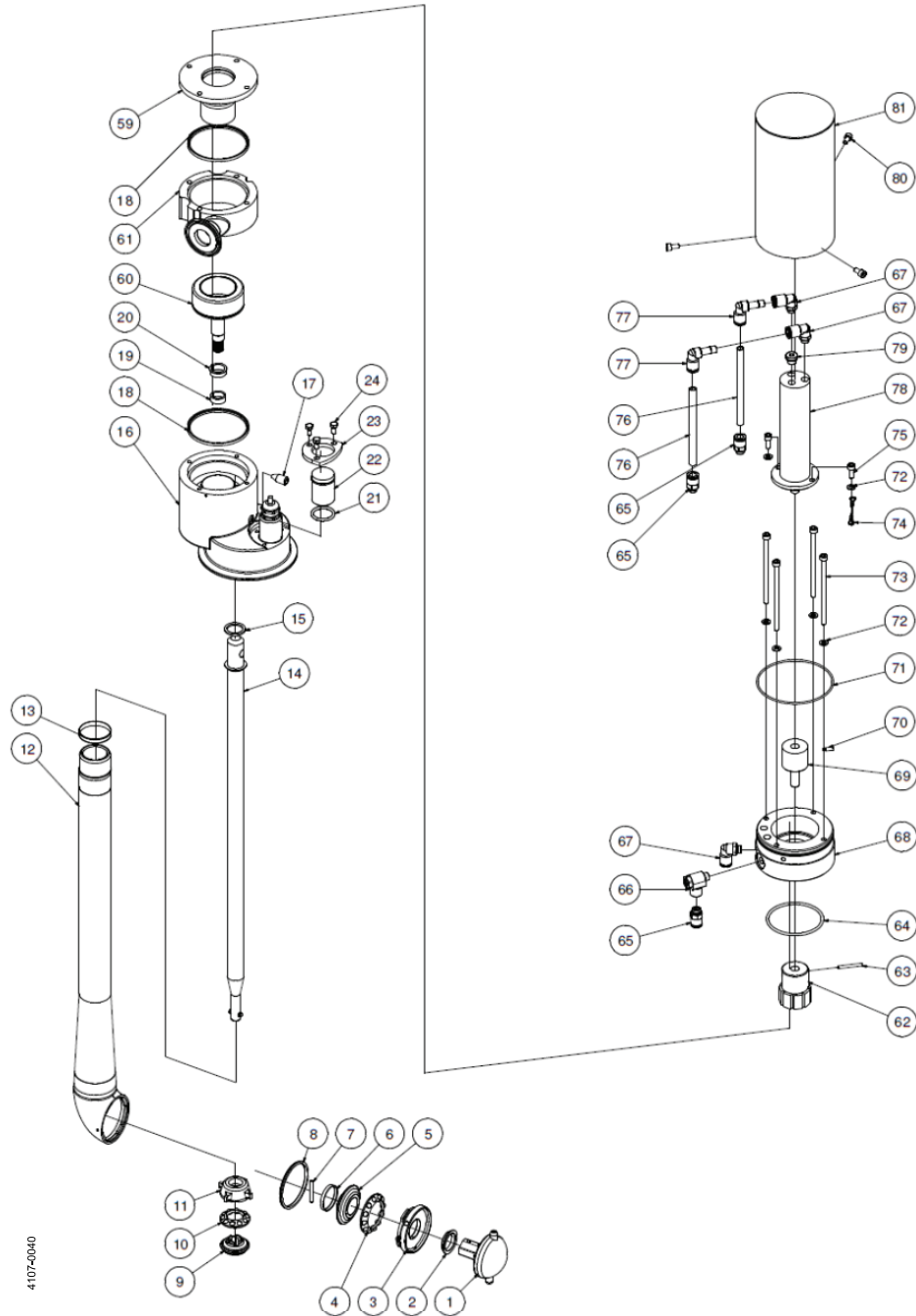

10 Parts drawings and lists, service kits and tools

Toftejorg SaniJet 20 Air driven

Parts list

Pos.	Qty	Denomination
1	1	Cleaner head
2	1	Bearing bush
3	1	Retaining ring
4	1	Ball ring N
5	1	Bevel gear
6	1	Clip ring
7	1	Pin
8	1	Seal ring H
9	1	Bevel gear
10	1	Ball ring
11	1	Ball race
12	1	Outer tube
13	1	Bearing ring
14	1	Inner shaft
15	1	Plain seal
16	1	Base housing
17	1	Retaining screw
18	2	Gasket
19	1	Bearing bush
20	1	Bearing bush
21	1	O-ring
22	1	Plug
23	1	Bracket
24	3	Screw
59	-	Motor flange welded A
60	1	Rotor outer complete
61	1	Inlet housing 1 Tri-clamp
62	1	Rotor inner w. magnets
63	1	Tubular rivet
64	1	O-ring
65	3	Straight connector
66	1	Flow control valve
67	3	L-connector
52	1	Flange for air motor
68		

Service kits

Denomination	Item no.
Service kits	
Service kit in PERLAST for Toftejorg SaniJet 20 air driven version	TE20C295

10 Parts drawings and lists, service kits and tools

Tottejorg SaniJet 20 Air driven

Parts marked with ○ are included in the Service kit PERLAST: TE20C295

Please note that some of the polymer parts are in PEEK, which is not resistant to concentrated sulfuric acid.

Configuration according to delivery note/order.

The machine can be delivered with ATEX/IECEX certification.

Please refer to the Spare Part Manual for information on item numbers and materials. The Spare Part Manual is available from the online Alfa Laval product catalogue Anytime or the Close at hand spare part catalogue.

10 Parts drawings and lists, service kits and tools

Toftejorg SaniJet 20 Air driven

10.4 Toftejorg SaniJet 20 Air Driven Hastelloy improved surface finish (FFKM as standard)

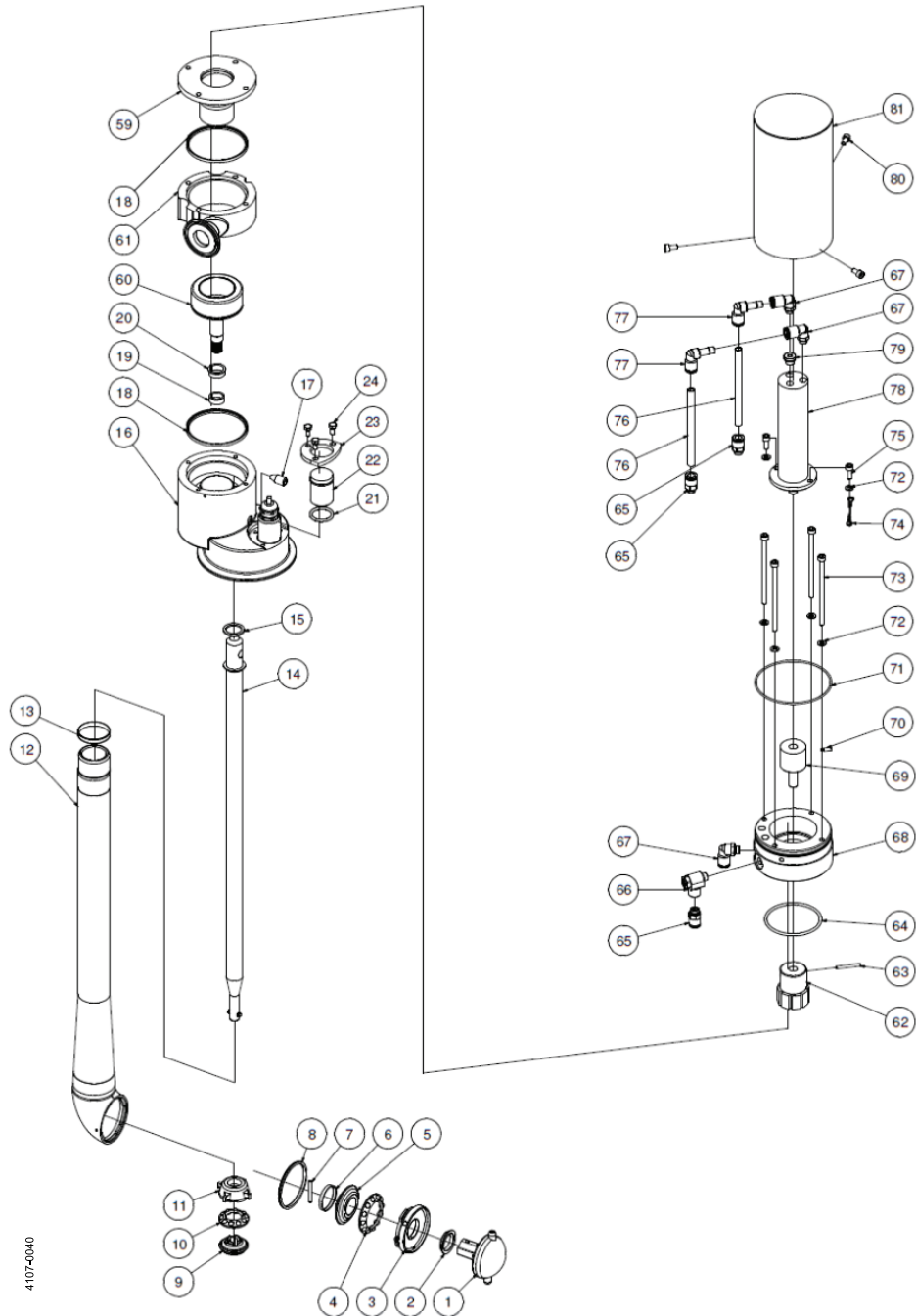

4107-0040

10 Parts drawings and lists, service kits and tools

Toftejorg SaniJet 20 Air driven

Parts list

Pos.	Qty	Denomination
1	1	Cleaner head
2	1	Bearing bush
3	1	Retaining ring
4	1	Ball ring N
5	1	Bevel gear
6	1	Clip ring
7	1	Pin
8	1	Seal ring H
9	1	Bevel gear
10	1	Ball ring
11	1	Ball race
12	1	Outer tube
13	1	Bearing ring
14	1	Inner shaft
15	1	Plain seal
16	1	Base housing
17	1	Retaining screw
18	2	Gasket
19	1	Bearing bush
20	1	Bearing bush
21	1	O-ring
22	1	Plug
23	1	Bracket
24	3	Screw
59	1	Motor flange welded A
60	1	Rotor outer complete
61	1	Inlet housing 1 Tri-clamp
62	1	Rotor inner w. magnets
63	1	Tubular rivet
64	1	O-ring
65	3	Straight connector
66	1	Flow control valve
67	3	L-connector
68	1	Flange for air motor

Service kits

Denomination	Item no.
Service kits	
Service kit in PERLAST for Toftejorg SaniJet 20 air driven version	TE20C295

10 Parts drawings and lists, service kits and tools

Tottejorg SaniJet 20 Air driven

Parts marked with ○ are included in the Service kit PERLAST: TE20C295

Please note that some of the polymer parts are in PEEK, which is not resistant to concentrated sulfuric acid.

Configuration according to delivery note/order.

The machine can be delivered with ATEX/IECEX certification.

Please refer to the Spare Part Manual for information on item numbers and materials. The Spare Part Manual is available from the online Alfa Laval product catalogue Anytime or the Close at hand spare part catalogue.

10.5 Service kits

Service intervals

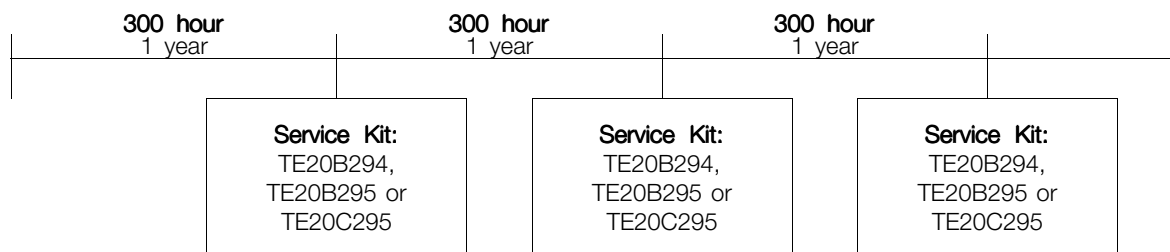

Service Kit in Viton for Alfa Laval Toftejorg SaniJet 20 air driven version

Article no. TE20B294

Parts list

Pos.	Qty	Denomination
8	1	Seal ring H
13	1	Bearing ring, top
15	1	Plain seal S
18	2	Gasket D
19	1	Bearing bush D2
20	1	Bearing bush D1
21	1	O-ring

Service Kit in EPDM for Alfa Laval Toftejorg SaniJet 20 air driven version

Article no. TE20B295

Parts list

Pos.	Qty	Denomination
8	1	Seal ring H
13	1	Bearing ring, top
15	1	Plain seal S
18	2	Gasket D
19	1	Bearing bush D2
20	1	Bearing bush D1
21	1	O-ring

10 Parts drawings and lists, service kits and tools

Toftejorg SaniJet 20 Air driven

Service Kit in Perlast for Alfa Laval Toftejorg SaniJet 20 air driven version

Article no. TE20C295

Parts list

Pos.	Qty	Denomination
8	1	Seal ring H
13	1	Bearing ring, top
15	1	Plain seal S
18	2	Gasket D
19	1	Bearing bush D2
20	1	Bearing bush D1
21	1	O-ring

Available add-on's regarding material certificates, Declaration of Compliance and Q-doc documents, see page 44 for more information.

10.6 Tools

Socket wrench w. pin TE462A
Hook spanner TE20B701

11.1 Service and repair

Upon every return of a product, no matter if for modifications or repair, it is necessary to contact your local Alfa Laval office to guarantee a quick execution of your request.

You will receive instructions regarding the return procedure from your local Alfa Laval office. Be sure to follow the instructions closely.

11.2 How to order spare parts

On the parts drawings as well as on all instruction drawings, the individual parts have a position number, which is the same on all drawings. From the position number, the part is easily identified in the parts lists, page ff.

Individual parts should always be ordered from the parts lists, page ff. Item number and denomination should be clearly stated.

Please refer to the Spare Part Manual for information on item numbers. The Spare Part Manual is available from the online Alfa Laval product catalogue Anytime or the Close at hand spare part catalogue.

Please also quote the type of machine and serial number. This will help us to help you. The type and serial numbers are laser engraved on the Base house of the tank cleaning machine.

Note: In cases where spare parts are ordered for machines originally delivered with Q-doc (Equipment Documentation), please state this information on your ordering form together with the machine type and serial number. This is to ensure full traceability henceforward.

Note: In connection with ordering of spare parts for machines originally delivered with Q-doc + FAT-SAT (Qualification Documentation) please note that all service and repair should be performed by Alfa Laval Kolding A/S, Denmark, see page 30 "6.5 Service and repair of machines ordered with Q-doc and with Q-doc + FAT-SAT".

11.3 How to contact Alfa Laval Kolding A/S

For further information please feel free to contact:

Alfa Laval Kolding A/S

31, Albuen - DK 6000 Kolding - Denmark

Registration number: 30938011

Tel switchboard: +45 79 32 22 00 - Fax switchboard: +45 79 32 25 80

www.toftejorg.com, www.alfalaval.dk - info.dk@alfalaval.com

Contact details for all countries are continually updated on our websites

How to contact Alfa Laval

Contact details for all countries are continually updated on our website.

Please visit www.alfalaval.com to access the information directly.

© Alfa Laval Corporate AB

This document and its contents is owned by Alfa Laval Corporate AB and protected by laws governing intellectual property and thereto related rights. It is the responsibility of the user of this document to comply with all applicable intellectual property laws. Without limiting any rights related to this document, no part of this document may be copied, reproduced or transmitted in any form or by any means (electronic, mechanical, photocopying, recording, or otherwise), or for any purpose, without the expressed permission of Alfa Laval Corporate AB. Alfa Laval Corporate AB will enforce its rights related to this document to the fullest extent of the law, including the seeking of criminal prosecution.